



Telecommunications Distribution

DESIGN GUIDE

PREPARED FOR:

CLEMSON[®]
NETWORK SERVICES AND
TELECOMMUNICATIONS

Telecommunications Distribution

DESIGN GUIDE

January 1, 2024

PREPARED BY:

Summit Engineering & Consulting, PS

PREPARED FOR:

Clemson University
Clemson Computing and Information Technology

Table of Contents

TABLE OF CONTENTS	3
1 PREFACE	8
1.1 INTRODUCTION	8
1.2 DOCUMENT INTENT	9
1.3 DOCUMENT STRUCTURE	11
1.4 STANDARDS AND GUIDELINES	12
1.5 LOW-VOLTAGE SYSTEMS	13
1.5.1 Shared OSP Media and Pathway	13
1.5.2 Shared ISP Media and Pathway	14
1.6 REQUIRED MANUFACTURERS (BASIS OF DESIGN).....	14
1.7 TYPES OF BUILDINGS AND SPACES	15
1.8 CONSTRUCTION TYPES	15
1.9 CLEMSON PERSONNEL	16
1.10 COPYRIGHT	17
2 PROJECT PROCEDURES	18
2.1 DESIGNER QUALIFICATIONS	18
2.2 DESIGN-BUILD CONTRACTOR QUALIFICATIONS	19
2.3 ARCHITECT/ENGINEER TEAMS.....	19
2.3.1 Cross-Discipline Coordination	19
2.3.1.1 OUTSIDE PLANT INFRASTRUCTURE.....	19
2.3.1.2 INDOOR UTILITIES AND FUNCTIONS.....	20
2.4 DESIGN REVIEW PROCESS.....	20
2.4.1.1 TYPICAL DOCUMENT REVIEW SCOPE.....	21
2.4.1.2 TYPICAL REVIEW PROCESS.....	23
2.5 GENERAL PROCEDURES	25
2.5.1 Procurement and Installation	25
2.5.2 CAD Files	25
2.5.3 Standards Variance Request (SVR).....	25
2.6 GENERAL PROCEDURES	29
2.6.1 Procurement and Installation	29
2.7 PROCEDURES RELATED TO PROJECT PHASES	29
2.7.1 Pre-Design	29
2.7.2 Schematic Design and Fieldwork	29
2.7.3 Design Development.....	30
2.7.4 Construction Documents	30
2.7.5 Bidding	31
2.7.5.1 DESIGN-BUILD BIDS.....	32
2.7.6 Construction Observation	32
2.7.6.1 PLUMBING AND PIPING.....	33
2.7.6.2 CABLE TRAYS.....	34
2.7.7 Post-Construction	34
2.8 DESIGNING FOR DEMOLITION	34
2.8.1 Site-Specific Code Requirements.....	35

2.8.2	Preservation Objectives	35
2.8.3	Salvage Objectives	35
3	DESIGN CRITERIA.....	36
3.1	PRINCIPLES OF TRANSMISSION.....	37
3.2	ELECTROMAGNETIC COMPATIBILITY.....	37
3.3	TELECOMMUNICATIONS SPACES.....	37
3.3.1	Telecommunications Room Location.....	38
3.3.2	Telecommunications Room Sizing	39
3.3.3	Architectural Provisioning	40
3.3.3.1	PLYWOOD BACKBOARDS.....	40
3.3.4	Environmental Provisioning	41
3.3.5	Plumbing	42
3.3.6	Fire Suppression Systems	42
3.3.7	Cable Tray Entrance.....	42
3.3.8	Floor-Standing Equipment Racks and Cabinets.....	43
3.3.8.1	EQUIPMENT RACKS	43
3.3.8.2	TELECOMMUNICATIONS CABINETS.....	44
3.3.9	Power Requirements	45
3.3.9.1	BACKUP POWER (GENERATOR & UPS).....	45
3.3.9.1.1	Life-safety Systems (NEC 700.1).....	46
3.3.9.1.2	Operationally Critical Systems (NEC 702.2).....	47
3.3.9.2	ELECTRICAL POWER PANELS	47
3.3.9.3	TECHNICAL POWER OUTLETS.....	50
3.3.9.3.1	For New Construction and Modernization Projects	52
3.3.9.3.2	For Minor Remodel Projects	52
3.3.9.3.3	For Remodel Projects	52
3.3.9.4	CONVENIENCE POWER OUTLETS.....	52
3.3.10	Grounding, Bonding, and Electrical Protection.....	53
3.3.11	Cables Entering Telecommunications Rooms	53
3.3.12	Prohibited Items.....	53
3.3.13	Entrance Facilities	53
3.3.13.1	OUTSIDE PLANT CONDUIT ENTRANCE.....	53
3.3.13.2	ROOFTOP CONDUIT ENTRANCE.....	54
3.3.14	Server Rooms.....	54
3.4	BACKBONE DISTRIBUTION SYSTEMS	54
3.4.1	Intra-building Backbone Pathways	54
3.4.1.1	BACKBONE RACEWAY SIZE AND QUANTITY REQUIREMENTS.....	55
3.4.1.1.1	Single-story Buildings.....	55
3.4.1.1.2	Multi-story Buildings	56
3.4.2	Intra-building Backbone Cabling.....	56
3.4.2.1	INTRA-BUILDING BACKBONE CABLE TYPES.....	57
3.4.2.2	STRAND AND PAIR COUNTS.....	57
3.4.2.3	CABLE SEGREGATION.....	57
3.4.2.4	INNERDUCT	57
3.4.3	Inter-building (Campus) Backbone Pathways	57
3.4.3.1	DUCTBANK.....	58
3.4.3.1.1	Conduit Types	58
3.4.3.1.2	Ground Conductor.....	59
3.4.3.1.3	Burial Depth and Slope	59
3.4.3.1.4	Conduit Sweeps (Bends)	59
3.4.3.1.5	Ductbank Encasement	60
3.4.3.1.6	Number of Ducts	60
3.4.3.1.7	Ductbank Length	60
3.4.3.1.8	Separation from Other Utilities	61

3.4.3.1.8.1	Proximity to Power or Other Foreign Conduits	61
3.4.3.1.8.2	Proximity to Water, Gas, or Oil Conduits	61
3.4.3.1.8.3	Proximity to Steam Lines and Steam Utilidors	62
3.4.3.1.8.3.1	Crossing Steam Utilidors	62
3.4.3.1.8.3.2	Direct Buried Steam Lines	63
3.4.3.1.9	Innerduct	63
3.4.3.1.10	Coordination with Utility Service Providers	63
3.4.3.2	MAINTENANCE HOLES AND HANDHOLES	63
3.4.3.3	AERIAL DISTRIBUTION	64
3.4.3.4	BRIDGE AND WATERWAY CROSSINGS	65
3.4.3.5	WIRELESS AND RADIO SYSTEM DISTRIBUTION	65
3.4.4	Campus Cabling	65
3.4.4.1	CABLING TYPE	65
3.4.4.2	UTILITY SERVICES	65
3.4.4.2.1	Non-Clemson Tenant Demarc	66
3.4.4.3	WIRELESS AND RADIO SYSTEM DISTRIBUTION	66
3.5	HORIZONTAL DISTRIBUTION SYSTEMS	66
3.5.1	Device Box Considerations	66
3.5.1.1	FLOOR BOXES	67
3.5.1.2	FOR NEW CONSTRUCTION AND FULL REMODEL	67
3.5.1.3	FOR OTHER PROJECTS	68
3.5.2	Work Areas	68
3.5.2.1	STANDARD TELECOMMUNICATIONS OUTLETS	68
3.5.2.2	PERMANENT OFFICE SPACES	69
3.5.2.2.1	Standard Offices (120 to 150 Square Feet)	70
3.5.2.2.2	Large Offices (150 Square Feet or larger)	70
3.5.2.3	OPEN OFFICE/MODULAR FURNITURE	70
3.5.2.4	TELECOMMUNICATIONS OUTLETS FOR WIRELESS ACCESS POINTS	72
3.5.2.4.1	Standard Provisions	73
3.5.2.4.2	Areas of Higher WAP Concentration	74
3.5.2.4.2.1	Fixed-seating Applications	75
3.5.2.4.2.2	Flexible-seating Applications	76
3.5.2.5	TELECOMMUNICATIONS OUTLETS FOR SPECIAL INDOOR APPLICATIONS	78
3.5.2.6	OUTDOOR WIRELESS ACCESS POINTS AND SURVEILLANCE VIDEO CAMERAS	79
3.5.2.6.1	Pole-mounted	80
3.5.2.7	WORKSTATION POWER OUTLETS	80
3.5.2.8	DEPARTMENTAL-SPECIFIC APPLICATIONS	80
3.5.2.8.1	Housing and Dining	81
3.5.2.8.2	Parking Services	81
3.5.2.8.3	Two-way Communication Devices for Elevator Landing	81
3.5.2.8.4	Security Cameras	82
3.5.2.8.5	Audio/Visual	82
3.5.2.8.6	Athletics Department	82
3.5.2.8.7	Security	82
3.5.2.8.8	Building Power Monitoring	82
3.5.2.8.9	Mechanical Systems	83
3.5.2.8.10	Academic	83
3.5.2.8.11	Other	83
3.5.2.8.12	Fire Alarm System	83
3.5.2.8.13	Emergency Phones, Elevator Phones, and Area of Refuge Phones	83
3.5.2.8.14	Lighting System	84
3.5.2.8.15	Emergency Responder Radio DAS	84
3.5.2.8.16	Telephone System	84
3.5.2.8.17	Mass Notification System	84
3.5.3	Horizontal Cabling Systems	84
3.5.3.1	GENERAL	84

3.5.3.2	TOPOLOGY	85
3.5.3.3	HORIZONTAL DATA APPLICATIONS	85
3.5.3.4	HORIZONTAL FIBER OPTIC CABLING APPLICATIONS	85
3.5.3.5	GPON HORIZONTAL CABLING SOLUTION	85
3.5.3.5.1	GPON Architecture	86
3.5.3.5.2	Academic and Administrative Buildings	86
3.5.3.5.3	Residence Halls	86
3.5.3.5.4	Outlets	86
3.5.3.5.5	Cable Trays	87
3.5.3.5.6	Innerduct for GPON Applications	87
3.5.3.5.7	ONT Installation	87
3.5.3.5.8	WiFi and Camera Applications	87
3.5.3.5.9	Analog Circuit Applications	87
3.5.3.5.10	Telecommunications Room sizing for GPON Applications	88
3.5.3.6	HORIZONTAL VOICE APPLICATIONS	88
3.5.3.7	LOW-VOLTAGE AND BUILDING AUTOMATION SYSTEMS	88
3.5.3.8	HORIZONTAL CROSS-CONNECT (HC)	89
3.5.3.9	PHYSICAL SEPARATION REQUIREMENTS	90
3.5.3.10	PATCH CORDS	90
3.5.4	Horizontal Pathway Systems	90
3.5.4.1	GENERAL PATHWAY DESIGN CONSIDERATIONS	90
3.5.4.2	PATHWAYS FOR NEW CONSTRUCTION AND MODERNIZATION PROJECTS	92
3.5.4.3	PATHWAYS FOR MINOR REMODEL AND TELECOMMUNICATIONS-ONLY PROJECTS	92
3.5.4.4	CABLE TRAY PATHWAY SYSTEMS	92
3.5.4.4.1	Cable Tray Clearances	94
3.5.4.4.2	General Pathway Design Considerations	95
3.5.4.5	CONDUIT AND JUNCTION BOX PATHWAY SYSTEMS	98
3.5.4.6	SURFACE RACEWAY	99
3.5.4.7	UNDERFLOOR DUCT SYSTEMS	100
3.5.4.8	ACCESS FLOORS	100
3.6	ITS CABLES AND CONNECTING HARDWARE	100
3.6.1	Copper Cabling	100
3.6.2	Fiber Optic Cabling	100
3.6.3	Splicing	101
3.7	FIRESTOP SYSTEMS	101
3.8	BONDING AND GROUNDING (EARTHING)	102
3.9	POWER DISTRIBUTION	102
3.10	TELECOMMUNICATIONS ADMINISTRATION	103
3.10.1	Identification Strategy	103
3.10.1.1	NEW TELECOMMUNICATIONS DISTRIBUTION SYSTEMS	103
3.10.1.2	MOVES, ADDS, AND CHANGES (MAC)	107
3.11	FIELD TESTING OF STRUCTURED CABLING	108
3.12	OUTSIDE PLANT	109
3.13	AUDIO/VISUAL SYSTEMS	109
3.13.1	Audio/Visual Systems	110
3.13.2	Private CATV Distribution Systems	110
3.14	BUILDING AUTOMATION SYSTEMS	110
3.14.1	Fire Alarm System	110
3.15	DATA NETWORKS DESIGN	111
3.16	WIRELESS NETWORKS	111
3.16.1	All Wireless Networks	111
3.16.2	WiFi Networks	112
3.16.3	Distributed Antenna Systems	112

3.16.3.1	EMERGENCY RESPONDER RADIO	112
3.16.3.2	CELLULAR TELEPHONE SERVICE AUGMENTATION.....	112
3.17	ELECTRONIC SAFETY AND SECURITY	112
3.18	DATA CENTERS	113
3.19	HEALTH CARE	114
3.20	RESIDENTIAL CABLING.....	114
3.21	BUSINESS DEVELOPMENT AND PROJECT MANAGEMENT	114
4	CONSTRUCTION DOCUMENT CONTENT.....	115
4.1	PLANS AND DRAWINGS	115
4.1.1	General	115
4.1.2	Outside Plant Site Plan Drawings.....	115
4.1.3	Maintenance Hole/Handhole Butterfly Diagrams.....	116
4.1.4	Inside Plant Plan Drawings.....	116
4.1.5	Demolition	117
4.1.6	Telecommunications Room Plan Details.....	117
4.1.7	Elevation Diagrams.....	118
4.1.8	Intra-building Backbone Schematic Diagrams.....	119
4.2	PROJECT MANUAL.....	119
4.2.1	Specifications.....	119
4.2.1.1	CLEMSON TELECOMMUNICATIONS CONSTRUCTION GUIDE SPECIFICATION	119
4.2.1.2	COMMON SPECIFICATION SECTIONS.....	120
4.2.2	Cutover Plan	120
4.2.3	Fiber Link-loss Budget Analysis.....	121
4.3	RECORD DRAWINGS AND DOCUMENTATION	121
4.3.1	Record Drawing Content	121
4.3.2	Record Drawing Deliverables	121
5	APPENDIX.....	122
5.1	CABLE COLOR SCHEME	122
5.2	SAMPLE RACK ELEVATION DETAILS	123
5.2.1	Two Racks	124
5.2.2	Three Racks.....	125
5.2.3	Four Racks.....	125
5.2.4	Five Racks and Six Racks	126
5.3	SAMPLE TELECOMMUNICATIONS ROOM PLAN DETAILS	126
5.3.1	Two Racks – 10' x 10' (interior dimensions).....	128
5.3.2	Three Racks – 10' x 12.5' (interior dimensions)	129
5.3.3	Four Racks – 10' x 15' (interior dimensions)	130
5.4	SAMPLE WALL ELEVATION DETAIL.....	131
5.5	SAMPLE MAINTENANCE HOLE BUTTERFLY DIAGRAM.....	132
5.6	SAMPLE FIBER OPTIC LINK-LOSS BUDGET ANALYSIS	133
5.7	ACRONYM GLOSSARY.....	134

1 Preface

1.1 Introduction

- A. The Telecommunications Distribution Design Guide (TDDG) is written to communicate the requirements of Clemson University (Clemson) for the design and installation of telecommunications distribution infrastructure at Clemson facilities.
- The TDDG is written for an audience of Architects, Engineers, and Designers who are responsible for the design of new or remodeled facilities for Clemson where telecommunications distribution systems currently exist or will be installed.
 - It is also intended for other low-voltage telecommunications Contractors installing telecommunications distribution systems at Clemson facilities.
 - This document also applies to infrastructure designed and installed by Clemson staff, when a formal design is not developed.
- B. Clemson University has prepared Guidelines for Commissioned Architects and Engineers (commonly referred to as the “Green Book”) to be applied to all Clemson facilities, located at:
<https://cufacilities.sites.clemson.edu/capital/green>
 The Technology Infrastructure Standards (of which the TDDG is a portion) are a set of documents within the Green Book umbrella that describe the requirements for technology infrastructure and systems at Clemson facilities.

Technology Infrastructure Standards Document Set

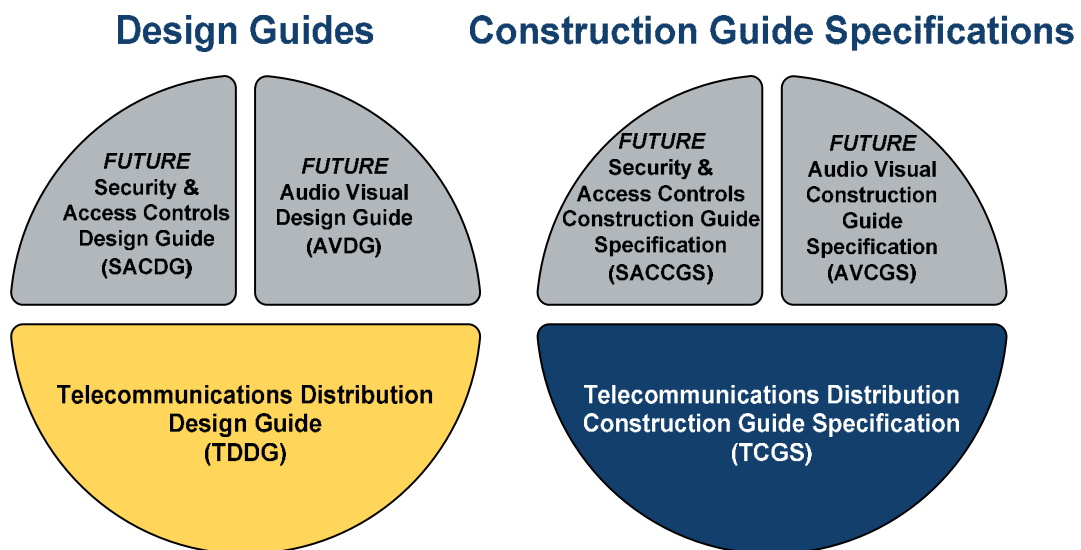

- Documents indicated as “Future” may be created later, but no commitment

has yet been made.

- C. The Telecommunications Construction Guide Specification (TCGS) is a key companion to the TDDG.
- Designers shall adapt the TCGS “as written” for creating specifications for a particular project according to the instructions in the TDDG. In other words, Designers shall use the electronic specification section documents (provided by Clemson in MSWord format) and then shall make any project-specific edits to the specifications in those documents. Any changes to the specifications shall be done using the “Revision Tracking” features in MSWord.
 - Rewriting the TCGS or modifying the format structure or requirements will not be accepted.
- D. Telecommunications distribution systems designed for Clemson are expected to support and integrate voice, data, video, and other low-voltage systems with common media (fiber optic and unshielded twisted pair (UTP) copper cable).
- E. The telecommunications distribution systems Designer shall coordinate with the other designers on a project (architectural, electrical, mechanical, etc.) to determine that other systems are both compatible with and complementary to the telecommunications distribution system. It is critical to coordinate between disciplines during the design phase of a project, rather than making adjustments in the field during construction.
- F. The telecommunications Designer shall design new systems to comply with the requirements of this document set and that are consistent with the existing infrastructure at Clemson.
- G. This document was prepared by the CCIT Network Services and Telecommunications (NST) department at Clemson University and by Summit Engineering & Consulting, P.S. As technology and needs evolve, the document will be periodically updated.
- August 2018 – Originally published
 - November 1, 2018 – Updated
 - July 1, 2020 – Updated
 - January 1, 2022 – Updated
 - January 1, 2024 - Updated

1.2 Document Intent

- A. The Design Process diagram below depicts the relationships between the ANSI/TIA/EIA Standards, the BICSI Design Guidelines, the Clemson documents (TDDG, TCGS) and the project-specific Construction Documents. Telecommunications distribution infrastructure at Clemson facilities shall be designed based on the BICSI Design Guidelines (the TDMM, the OSPDRM and the ITSIMM) and compliant with the ANSI/TIA/EIA Standards as applied by and

illustrated in the Clemson TDDG.

- B. The TDDG is intended to be used in conjunction with the TDMM and OSPDRM in order to reinforce selected TDMM content as well as highlight any restrictions and/or limitations on TDMM and OSPDRM content in order to meet the specific requirements of Clemson facilities. The TDDG is not intended to replace or detract from the TDMM or OSPDRM.

The Design Process

Based on Industry Standards and Guidelines and Clemson’s Design Guide and Guide Specifications

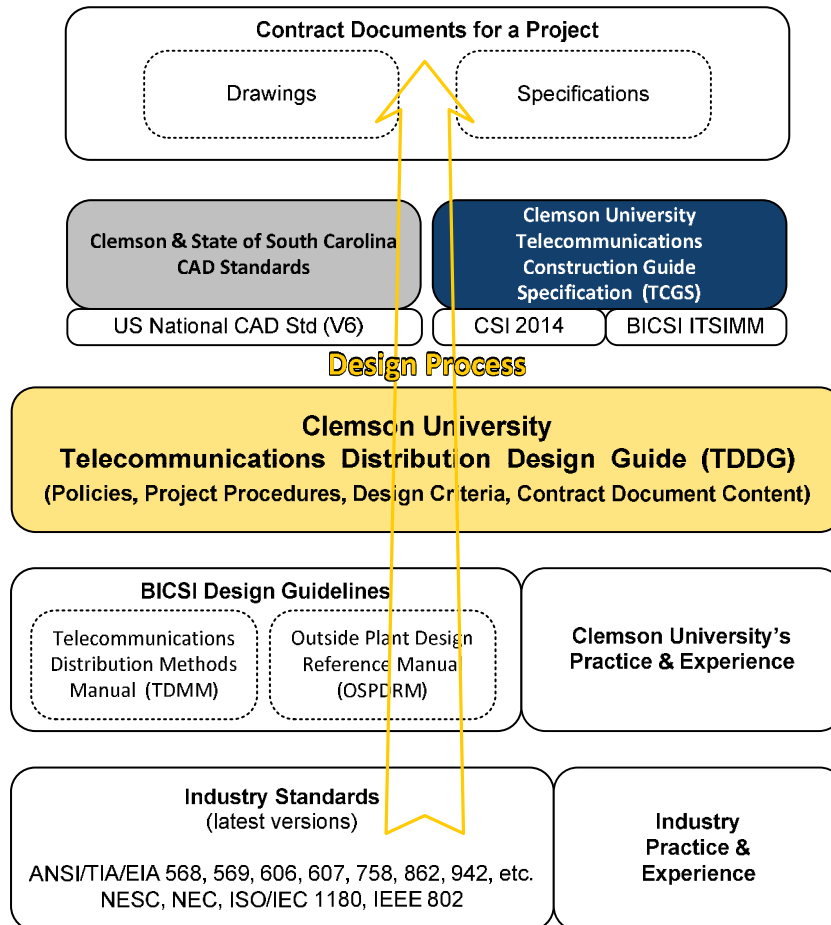

- C. This document provides directions for making standards-compliant design decisions that will, in due course, be reflected in Construction Documents. The Construction Documents for a project will consist of drawings and a specification that properly incorporates telecommunications infrastructure within a project. The TDDG shall be used in conjunction with the TCGS. Drawings shall conform to the guidelines contained in this document for content and completeness, and

the specifications shall be based upon the TCGS.

- D. The TDDG is not intended to serve as a master specification nor for stand-alone use on design-build projects. This document should serve as a guide for making standards-compliant design decisions that, in due course, will be reflected in a project specification based upon the TCGS.
- E. The TDDG uses many terms and abbreviations that are common in the telecommunications industry. Please refer to the Glossary in the BICSI TDMM and also the Glossary section at the end of the BICSI OSPDRM for definitions.

1.3 Document Structure

The TDDG is organized in the following sections:

1. The **Preface** (this section) describes this document, its intent, and its relationship to industry standards, practices and the various audiences affected by the document. It also describes how to use this document.
2. The **Project Procedures** section describes the required qualifications for telecommunications Designers as well as the procedures that Designers must follow when working on telecommunications infrastructure projects at Clemson facilities. It includes activities that are required throughout the project as well as phase-specific requirements.
3. The **Design Criteria** section serves two purposes. The first is to describe the general requirements for Clemson telecommunications infrastructure along with the typical features required for different categories of building spaces and construction types. The second purpose is to place limitations on the materials and methods described in the BICSI TDMM and OSPDRM. While the TDMM and OSPDRM describe many materials and methods that are generally accepted in the industry for providing telecommunications infrastructure, Clemson facilities have some unique characteristics that restrict some of the materials and methods that otherwise might be acceptable. Some of the practices discussed in the TDMM and OSPDRM are expressly prohibited in Clemson facilities. Other practices are permitted in certain areas (residential halls, for example) but prohibited in other areas such as academic buildings.

Generally speaking, if the BICSI TDMM and OSPDRM do not describe a particular material or method for use with telecommunications distribution infrastructure, it will not be allowed for Clemson facilities. In addition, the Clemson TDDG places additional restrictions on the use of some materials and methods that the BICSI design guidelines support.

4. The **Construction Document Content** section defines the minimum level of detail that Clemson requires to be present in the telecommunications portion of the Construction Documents for a project. In this section, the required types of details along with the content in the details, are both described. This section also briefly describes the specifications that are required for a project.

5. The **Appendices** section provides examples and standard forms and diagrams that are required for Clemson telecommunications infrastructure.

1.4 Standards and Guidelines

- A. Clemson has standardized on the ANSI/TIA/EIA Commercial Building Telecommunications Standards series and has adopted the following BICSI¹ design guide documents as the basis for telecommunications distribution design in Clemson facilities:

- BICSI Telecommunications Distribution Methods Manual (TDMM) (14th Edition)
- BICSI Outside Plant Design Reference Manual (OSPDRM) (6th Edition)
- BICSI Information Transport Systems Installation Methods Manual (ITSIMM) (7th Edition)

The Clemson TDDG is the guide to the application of the ANSI/TIA/EIA Standards, the BICSI TDMM, the BICSI OSPDRM, and the BICSI ITSIMM to the unique circumstances present in Clemson facilities and projects.

All references to these manuals shall specifically address only the editions specified above. Newer editions shall be used “for reference only” until authorized by Clemson in writing or through a revised edition of the TDDG.

- B. Adherence to and compliance with the codes, standards, and industry practices listed below, along with the Clemson requirements contained in this document, is mandatory:

- Clemson Facilities Design and Construction Standards
- 2009 International Building Code
- *National Electrical Safety Code*, American National Standards Institute C2
- *National Electrical Code (NEC)*, National Fire Protection Association (NFPA 70)
- *Manual of Practice*, Firestop Contractors International Association (FCIA)
- ANSI/TIA/EIA 568-C series – *Commercial Building Telecommunications Standards*
- ANSI/TIA/EIA 569-C series – *Telecommunications Pathways and Spaces*
- ANSI/TIA/EIA 606-B series – *Administration Standard for Telecommunications Infrastructure*
- ANSI/TIA/EIA 607-B series – *Generic Telecommunications Grounding (Earthing) and Bonding Requirements for Customer Premises*
- ANSI/TIA/EIA 758-B series – *Customer-Owned Outside Plant Telecommunications Infrastructure Standard*
- ANSI/TIA/EIA 862-A – *Building Automation Systems Cabling Standard*
- ANSI/TIA/EIA 942-A – *Telecommunications Infrastructure Standard For Data Centers*

¹ BICSI is widely considered to be the industry source for standards-compliant design guidelines for telecommunications distribution systems. See www.bicsi.org for additional information.

- ANSI/BICSI 005-2016 – *Electronic Safety and Security (ESS) System Design and Implementation Best Practices*
 - TIA/EIA 455 (Series) – *Standard Test Procedures for Fiber Optic Systems*
 - TIA/EIA 526 (Series) – *Optical Fiber Systems Test Procedures*
 - IEEE 802.3 (Series) – *Ethernet*
 - IEEE 802.11 (Series) – *Wireless LANs*
- C. The requirements in these documents apply to all technology infrastructure installed in Clemson facilities including inside plant infrastructure serving most non-Clemson tenants.
- D. Any request to deviate from the requirements of the National Electrical Code will not be accepted.
- E. The Designer shall seek approval for designs that are not consistent with Clemson TDDG requirements. Requests to deviate from industry standards or Clemson design solutions will be considered on a case-by-case basis by the CCIT Technical Lead. Designers shall contact the CCIT Technical Lead to discuss proposed alternatives before spending significant time pursuing the option.
- F. The requirements contained in the TDDG are considered to be in addition to those required under contract with the State of South Carolina. Where the requirements differ, the issue shall be brought to the attention of the Clemson Facilities Project Manager and the assigned CCIT Technical Lead – otherwise the more stringent requirement shall apply.

1.5 Low-Voltage Systems

Wherever practical, telecommunications pathway and cabling systems designed for Clemson facilities are expected to support and integrate the complete set of building automation systems and other low-voltage systems that convey information and operate facilities, and provide capacity for future growth. Telecommunications infrastructure shall be designed in accordance with the requirements in ANSI/TIA/EIA 862 – *Building Automation Systems Cabling Standard for Commercial Buildings*, and the requirements in this document, to support the Ethernet telecommunications channels on low-voltage devices. Throughout this document, references to “low-voltage systems” shall include those referenced in ANSI/TIA/EIA 862, and shall be subject to specific requirements in that standard and as discussed below.

1.5.1 SHARED OSP MEDIA AND PATHWAY

- A. The common outside plant (OSP) telecommunications media (cabling) shall be singlemode fiber optic cable. The common OSP telecommunications media and pathway are intended for shared use by all low-voltage systems on campus (not just voice and data systems).
- B. Multimode fiber optic cabling shall not be installed at Clemson facilities.

- C. OSP copper at Clemson facilities is utility-provided. The University typically does not install OSP copper cabling.

1.5.2 SHARED ISP MEDIA AND PATHWAY

- A. The common inside plant (ISP) telecommunications **pathway** is intended for **shared** use by all low-voltage systems (not just voice and data systems).
- B. The common inside plant telecommunications media shall be singlemode fiber optic backbone cabling, Category 6A-rated UTP copper cable for analog backbone, and Category 6A-rated UTP copper cable for horizontal applications. Inside plant **backbone** cabling is dedicated for use by the telecommunications, data network and VOIP telephone system. Backbone cabling is **not shared** with other low-voltage systems. **Horizontal** cabling serving these systems shall be dedicated (**not shared**) to each application.
- C. Multimode fiber optic cabling shall not be installed at Clemson facilities. Only singlemode fiber optic cabling is permitted.
- D. Inside plant telecommunications infrastructure intended to support Ethernet telecommunications (or other similar protocols for security, building automation, environmental, and fire alarm systems) shall be designed in accordance with the inside plant telecommunications infrastructure requirements in this document and coordinated with the CCIT Technical Lead. However, due to the critical nature of these systems, inside plant pathway and cabling serving these systems shall typically homerun to a Mechanical Room or other Low-Voltage Electronics Room rather than to a common shared Telecommunications Room.
- E. Where low-voltage systems require different media (other than singlemode fiber optic cabling and Category 6A UTP), the systems shall be designed to comply with the pathway and space requirements of this document. Clemson anticipates the future convergence of most low-voltage systems and requires the pathways and spaces to be designed now to support telecommunications cabling in the future.
- F. The Designer shall design pathway and cabling to serve these systems, in cooperation with the other design disciplines on a project.

1.6 Required Manufacturers (Basis of Design)

Telecommunications distribution systems shall be designed for construction using materials from the current product lines of the manufacturers required by Clemson.

- A. Currently the basis of design is defined as solutions comprised of CommScope (formerly TE) and Corning (unless otherwise directed by Clemson). Designs shall comply with the requirements of these manufacturers such that the manufacturers will certify the installation with their warranties. The construction documents shall require that the Contractor's installation workmanship fully comply with the current installation requirements from the manufacturers of these

products, even if those requirements exceed industry standard practices.

- For copper cabling termination materials, Clemson requires CommScope products.
 - For fiber optic cabling and termination materials, Clemson requires Corning products.
 - For GPON fiber optic cabling and related materials, Clemson requires Corning fiber optic products and Nokia electronics.
 - For equipment racking-related materials, Clemson requires Chatsworth or B-Line products.
 - All telecommunications room racks shall be of steel construction.
- B. The Designer shall incorporate a manufacturer consistently throughout the entire project (unless otherwise directed by Clemson) and design a telecommunications distribution system that will be suitable for the use of products from this manufacturer.

Required manufacturers and their products are identified in the TCGS.

- For example, ladder racking in all telecommunications rooms shall be manufactured by a single manufacturer and cabling system materials shall be manufactured by a single manufacturer. However, it is not required that cabling and ladder racking be from the same manufacturer.

The construction documents shall require that the installation workmanship fully comply with the current installation requirements from the manufacturers of these products.

1.7 Types of Buildings and Spaces

Many of Clemson's buildings have multiple building-type spaces within the building. For example, an academic building will have academic spaces and office spaces, and may also have research spaces, public gathering spaces, etc.

The Designer shall assume that adherence to BICSI guidelines, referenced industry standards, and Clemson's standards are required (unless specifically indicated otherwise) for all facility types. Where exceptions are permitted, this document set will specifically highlight the construction type(s) where Clemson's requirements may differ from generally applicable practices and standards.

Adherence to applicable Code is always required.

1.8 Construction Types

The Designer shall assume that adherence to BICSI guidelines, referenced industry standards, and Clemson's standards are required (unless specifically indicated otherwise) for all extents-of-construction and contracting models (design-bid-build, design-build, etc.). Where exceptions are permitted, this document will specifically

highlight the construction type where Clemson’s requirements may differ from generally applicable practices and standards.

Adherence to applicable Code is always required.

1.9 Clemson Personnel

- A. There are several defined Clemson personnel roles referenced in this document. The Designer shall interact with these individuals as direct points of contact:
- **Facilities Project Manager (FPM)** – responsible for project management, project oversight and project budget. There are four organizations from which the FPM could be assigned:
 - Capital Projects (CP)
 - Facilities Construction and Renovation (FC&R)
 - Housing and Dining (H&D)
 - Clemson University Athletics Department (CUAD)
 - **Technical Leads (TL)** – responsible for oversight of an assigned subset of Clemson’s technology considerations, including interpretation of the requirements of this document. There are four designated Technical Leads:
 - **CCIT Network Services and Telecommunications Technical Lead (NSTTL)** – responsible for fiber optic cabling, telecommunications rooms, outside plant pathways, and cabling and distributed antenna systems. The NSTTL role is typically assigned to a representative from the Network Services & Telecommunications department within CCIT.
 - **Audio/Visual Technical Lead (AVTL)** – responsible for oversight of all technology considerations related to the audio/visual infrastructure, related systems, and digital signage. The AVTL may be a designated representative from the Customer Relations and Learning Technology (CRLT) organization.
 - **Security Systems Technical Lead (SSTL)** – responsible for access control systems, video surveillance infrastructure, and intrusion detection systems. The SSTL may be a designated representative from Clemson’s TigerOne organization.
 - **Building Automation Technical Lead (BATL)** – responsible for building automation systems and environmental control systems.
 - **Clemson Computing & Information Technology Project Manager (CCITPM)** – responsible for administrative project management within the CCIT organization. All project-related communications should be addressed to the appropriate Technical Lead (above) with a copy to the assigned CCITPM.
- B. The Clemson Telecommunications Policy section of this document applies specifically to Clemson personnel. In addition to the Clemson

Telecommunications Policy section, Clemson personnel should be aware of the instructions, requirements and guidelines for Designers contained in the other sections of this document. Also, the TCGS contains additional requirements related to telecommunications distribution system materials and installation methods applicable at Clemson facilities.

- C. Clemson personnel should be familiar with these requirements with respect to their application on both large-scale telecommunications distribution projects and small-scale “moves/adds/changes” projects. These requirements also apply to in-house operations and maintenance of existing telecommunications distribution systems.

1.10 Copyright

Summit Engineering & Consulting retains the copyright for this document. Clemson University is authorized to edit and adapt the document.

Summit Engineering & Consulting has authored similar documents for many other organizations. The document is intended (in part) to describe best practices that are found in some segments of the industry. As a result, portions of this document are similar to comparable content in documents previously prepared by Summit Engineering & Consulting for other organizations. This document does not contain any information that is proprietary or confidential to other organizations.

2 Project Procedures

- A. The Project Procedures section contains guidelines for architects, engineers and telecommunications distribution designers regarding the procedures that Clemson requires for projects that include telecommunications distribution systems. This applies both to projects that entail primarily telecommunications distribution work (such as telecommunications infrastructure replacement projects) as well as to architectural projects and other work (such as a new building) that involve telecommunications design.
- B. This section is not intended to supersede State of South Carolina contract requirements, but rather to complement them, providing additional requirements that apply specifically to telecommunications design projects at Clemson facilities.
- C. It is intended that the requirements in this section be considered contractually binding for professional design firms providing telecommunications design services.

2.1 Designer Qualifications

- A. For the purposes of this document, the term “Designer” shall mean a person who is a Registered Communications Distribution Designer (RCDD) who is currently in good standing with BICSI. Telecommunications designs on Clemson projects shall be produced by the RCDD. This means that the telecommunications design shall be produced by the Designer. The RCDD shall be a fulltime employee of the design firm, not a third party providing oversight of a non-RCDD Designer’s work. Clemson’s communications with the telecommunications consultant shall be mainly through the RCDD. On projects where the RCDD is not the prime consultant, the RCDD shall keep the prime consultant (Architect/Engineer (A/E)) informed of all direct communications with Clemson.
- B. In addition to the RCDD certification, it is preferred that the RCDD have one or more of the following qualifications.
 - Professional Engineer (P.E.) in the electrical engineering field
 - RCDD/ESS certification from BICSI
 - RCDD/OSP certification from BICSI
 - WD from BICSI, or other similar industry certifications
- C. In addition, the RCDD shall have the following qualifications.
 - The RCDD shall demonstrate a minimum of 5 years of experience in the design of inside plant telecommunications distribution systems. Experience designing telecommunications infrastructure on Clemson projects is desirable, but is not required.
 - Experience not directly related to the design of telecommunications distribution systems, such as sales and/or marketing, project management, or

- installation experience, is not sufficient.
 - The RCDD shall have personal design experience or design oversight of a minimum of five projects similar in size and construction cost to the current Clemson project.
 - The RCDD shall be independent from and unaffiliated with any manufacturer associated with the telecommunications distribution system industry.
 - The RCDD shall be completely familiar and conversant with industry and Clemson telecommunications standards.
- D. The services of a professional engineer (PE) shall be required to design the following aspects of a complete technology infrastructure.
- Grounding and bonding
 - Firestopping
 - Electrical power distribution in telecommunications spaces
 - Standby generator and associated other backup power systems
 - Telecommunications room cooling systems
- E. The services of a licensed fire protection engineer shall be required to design fire protection and life safety systems.

2.2 Design-Build Contractor Qualifications

For Design-Build projects, the contractor must include a telecommunications design subcontractor who meets the qualifications requirements in the TCGS in Section 27 05 00. In addition, the subcontractor's telecommunications infrastructure designer must meet the requirements listed above under 2.1 *Designer Qualifications*.

2.3 Architect/Engineer Teams

It is imperative that the technology infrastructure design be incorporated during the preliminary architectural design phase. To accomplish this, the architects and engineers on the design team shall work closely with the Designer, the Clemson FPM, and the Clemson Technical Lead beginning with the Pre-Design phase of the project.

2.3.1 CROSS-DISCIPLINE COORDINATION

Successful projects involving technology infrastructure require frequent, thorough design coordination between the disciplines involved in the project. The Designer shall be primarily responsible to coordinate the technology requirements and design features with the designs produced by the other Designers on the project.

At a minimum, the following aspects of the design shall be coordinated:

2.3.1.1 OUTSIDE PLANT INFRASTRUCTURE

- Ductbank routing around obstacles (trees, tunnels, buildings, existing ductbanks,

- etc.).
- Locations of maintenance holes and hand holes to determine that they are not located in areas of water concentration. Site requirements, drainage, traffic, joint usage, utility requirements, etc.
- Proximity of ductbanks to sources of EMI (electromagnetic interference), including power distribution feeders.
- Proximity of ductbanks to steam piping.
- Routing of entrance conduits through buildings.
- Backbone cabling requirements of other disciplines (fire alarm, HVAC, security, CATV, etc.).

2.3.1.2 INDOOR UTILITIES AND FUNCTIONS

- HVAC cooling requirements for telecommunications rooms (TR) and A/V equipment rooms.
- HVAC ductwork routing (avoiding TR ceiling spaces and A/V equipment room spaces, and allocating space to access cable trays).
- Routing of wire basket cable trays through ceiling spaces in congested areas (HVAC ductwork, plumbing, electrical, etc.).
- Plumbing routing (avoiding TR spaces and A/V equipment room spaces).
- Lighting requirements for TRs, A/V equipment rooms, classrooms and conference rooms
- Power requirements for TRs and A/V equipment rooms.
- Power requirements for work areas (receptacle locations near telecommunications outlet locations and other devices).
- Proximity of cabling to sources of EMI.
- Routing of conduits through and location of pullboxes in congested areas (HVAC ductwork, plumbing, electrical, etc.).
- Walls, paint, doors and floors in TRs and A/V equipment rooms.
- Proximity of microphone and speaker wiring to sources of EMI.
- Acoustic treatments for Classrooms, Auditoriums and Conference Rooms.

More information regarding the above requirements is available below in Section 3 *Design Criteria*.

2.4 Design Review Process

The project documents shall pass through the design review process at the end of each design phase as well as follow-up reviews when necessary. These requirements are in addition to the State of South Carolina contract requirements.

On some projects, NST may hire an Independent Review Consultant to provide technical project oversight to Clemson. The Independent Review Consultant will be responsible to review the overall design, paying particular attention to areas of the design that are related to the current or future operation and maintenance of the technical systems, including low-voltage systems other than voice and data. The Independent Review Consultant will identify issues that do not appear to be compliant with the requirements in Clemson's Technology Infrastructure Standards.

2.4.1.1 TYPICAL DOCUMENT REVIEW SCOPE

NST Reviewers shall review the documents according to Clemson’s requested review scope and then produce a report that addresses at a minimum the following items:

- Review telecommunications system design:
 - For compliance with Clemson and industry standards
 - To identify apparent conflicts (routing, EMI, etc.) with other disciplines’ designs
 - For indications of coordination with utility service providers or other underground utilities
 - For general document clarity
- Review the completed needs analysis report.
- Review the cutover plans.

Item	Components to be Reviewed	Issues to be Considered
Pathways	Horizontal Conduit	Sizing, Sweep Radius
	Cable Tray	Sizing, Type
	Riser Conduit	Sizing, Sweep Radius
	Riser Sleeves	Sizing
	Firestopping	Locations, Type
	OSP Ductbank	Routes, Sizing, Sweep Radius

Spaces	Data Centers	Location, Sizing, Racks, Cable Protection and Termination, Grounding & Bonding
	Telecommunications Rooms and A/V Equipment Rooms	Location, Sizing, Racks, Cable Protection and Termination, Space for Wall-mounted Systems, Grounding & Bonding
	Application Spaces	Appropriate Arrangement of Conference Rooms and Classrooms
	Riser Shafts	Sizing, Vertical Stacking
	Maintenance Holes	Sizing, Location, Type

Item	Components to be Reviewed	Issues to be Considered
Cable Plant	Horizontal	CAT6A Copper, SM Fiber Optic
	Riser	UTP Copper, SM Fiber Optic
	Testing & Administration	Copper, SM Fiber Optic, Labeling Plan
Devices	Audio/Visual	Appropriate locations and quantities of A/V equipment, video surveillance devices and corresponding cabling
	Display	Appropriate locations and quantities of displays, digital signage equipment, and corresponding cabling

The following form is available in MSWord format for recording review comments:



DESIGN REVIEW COMMENTS

Date: 7/15/2018 Page: 1 of 2

Project Title	Clemson University	Contract No.	Architect:	Architect Name
	Project Title	CU #		

DWG. NO./ PAR. NO.	ITEM NO.	Reviewer Initials	REVIEWER COMMENTS	Initials / Firm	DESIGN TEAM RESPONSE
Sheet #	1	WC	Drawing Comment		
Sheet #	2	TS	Drawing Comment		
Sheet #	3	KH	Drawing Comment		Design Team Responses (Architects, Engineers, Designers)
Section # Para. #	4	KH	Specification Comment		
Section # Para. #	5	BT	Specification Comment		

NETWORK SERVICES & TELECOMMUNICATIONS
 120 McGinty Court, Barre Hall Room B-100, Clemson, SC 29634-2809
 Phone (864) 656-9302 – Fax (864) 656-0333

2.4.1.2 TYPICAL REVIEW PROCESS

The following steps correspond to the numbered activities shown on the Design Review Process diagram below:

① Each time a review is required, the Architect/Engineer shall provide copies of the complete project documents set (drawings and specifications for all disciplines involved in the project) for the following people:

- Clemson Facilities Project Manager (FPM) (one set)
- Each Clemson Technical Lead (xxTL) (one set)

②③④ The Clemson FPM and the Clemson Technical Lead will have 5, 8, or 10 days (depending on the project phase) to review the design documents and the Independent Review Consultant's comments. The Clemson Technical Lead will incorporate the Independent Review Comments into the Technical Lead's report. Following their review, they will distribute the complete set of comments to the Independent Review Consultant (if present on the project) and hold brief discussions about the comments. The Clemson Technology Review Comments will then be sent to the Clemson FPM for review.

⑤⑥ The Clemson FPM will submit the Technology Review Comments to the Designer. The Designer will then be given five days to review the comments and respond to them in writing. Negative responses to any comment shall include a discussion of the reasons for non-compliance.

⑦⑧ Finally, a meeting or teleconference will be held with the Clemson FPM, the Clemson Technical Lead, the Independent Review Consultant, and the Designer to discuss the review comments and the Designer's responses. Following the meeting, the Designer shall revise the design in accordance with Clemson's resolution for each comment.

Design Review Process

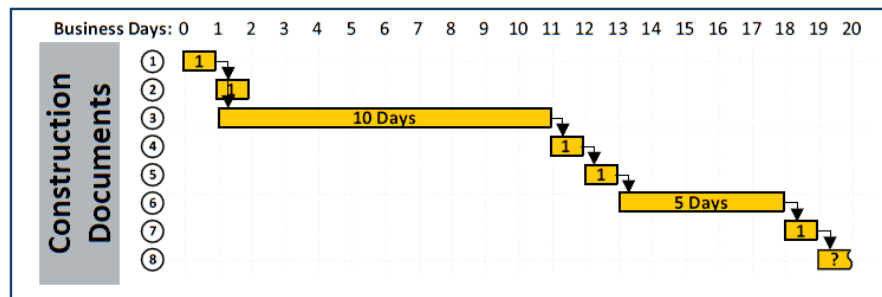
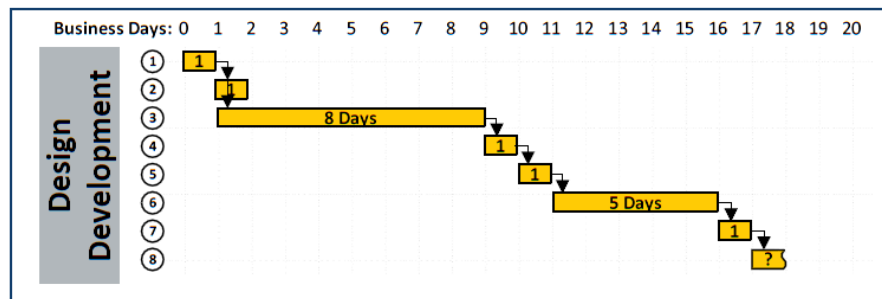
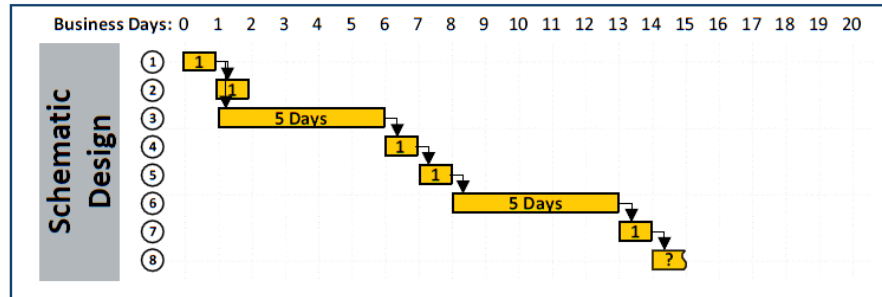

1. Designer sends hard copy printed Drawings and Specifications to the CCIT NST Technical Lead and Facilities Project Manager.
2. Clemson's FPM reviews the drawings and specifications.
3. Clemson's NSTTL reviews the drawings and specifications and then produces Review Comments.
4. Clemson's FPM and NSTTL meet to discuss and finalize the Review Comments.
5. Clemson's FPM issues the Technology Review Comments to the Designer for response.

6. Designer provides a written response for each Review Comment and returns the Review Comments to Clemson's FPM.
7. Clemson's FPM and NSTTL meet to discuss the Designer's responses to the Review Comments and determine a course of action for each item.
8. Designer shall revise the design per the direction given in Step 7 (above). Designer shall then submit a second written response indicating how each Review Comment was resolved.

2.5 General Procedures

2.5.1 PROCUREMENT AND INSTALLATION

A. The Designer shall inquire which procurement method will be used for a particular project. The construction documents prepared by the Designer shall be suited for the procurement method designated for the project. Some examples of procurement methods used at Clemson include:

- Design-Bid-Build
- Design-Build
- General Contractor/Construction Manager (GC/CM)
- Blanket Purchase Agreement
- State Master Contract
- Direct to Contractor
- Request for Bid/Request for Proposal
- Job Order Contracting
- Owner Provided & Integrated

2.5.2 CAD FILES

The Designer shall coordinate with the Prime Consultant (typically the Architect) to determine that the electronic CAD files used for backgrounds for the technology infrastructure and systems design are consistent with the CAD file backgrounds used by the other disciplines on the project.

2.5.3 STANDARDS VARIANCE REQUEST (SVR)

- A. It is not the intent of Clemson to rigidly impose standards on every aspect of a design. Each design is unique and special requirements may lead to situations that warrant deviations from the standards.
- B. Clemson's Technology Infrastructure Standards document set identifies specific design solutions that are intended to meet the technical requirements at most Clemson facilities. Design issues that are not consistent with the requirements in this document shall require prior approval through the Clemson Standards Variance Requests (SVR) process. Requests to deviate from industry standards or Clemson design solutions will be considered on a case-by-case basis. Any request to deviate from applicable code requirements or from manufacturer's warranty requirements will not be approved.
- C. If the Designer feels that a solution is warranted which differs from a given standard, the Designer shall submit a written Standards Variance Request to Clemson. The Designer may, upon written approval from Clemson, incorporate the design deviation into the overall design. Clemson approval is required on a project-by-project basis, and applies only to the designated instance(s) within that project. The Designer shall not assume that an approval for one project or

one instance means that the practice is approved for use throughout that project, or that it will necessarily be approved for a subsequent project.

The request shall include a complete description of the proposed alternative design identifying:

- The type of facility;
 - The conditions at the facility;
 - The approved design solution as described in this document or as described in the standards referenced in this document;
 - The proposed alternative design;
 - A list of the guidelines and standards referenced in this document with which the alternative design will not be in compliance, and the effect of non-compliance, both short and long term;
 - The reason for wishing to use the alternative design;
 - The Contractor or personnel performing the construction;
 - A written statement indicating that the proposed alternative design will meet the applicable Clemson system performance requirements, and identifying any performance limitations, drawbacks, and benefits from using the alternative design.
- D. Both the Designer and the Prime Consultant (typically the Architect) on the project shall be jointly responsible to determine that the SVR process is properly conducted, and shall participate in the process (review, acknowledge, and address issues) to determine that Clemson's requirements are met.

Approval Process for Standards Variance Requests (SVR)

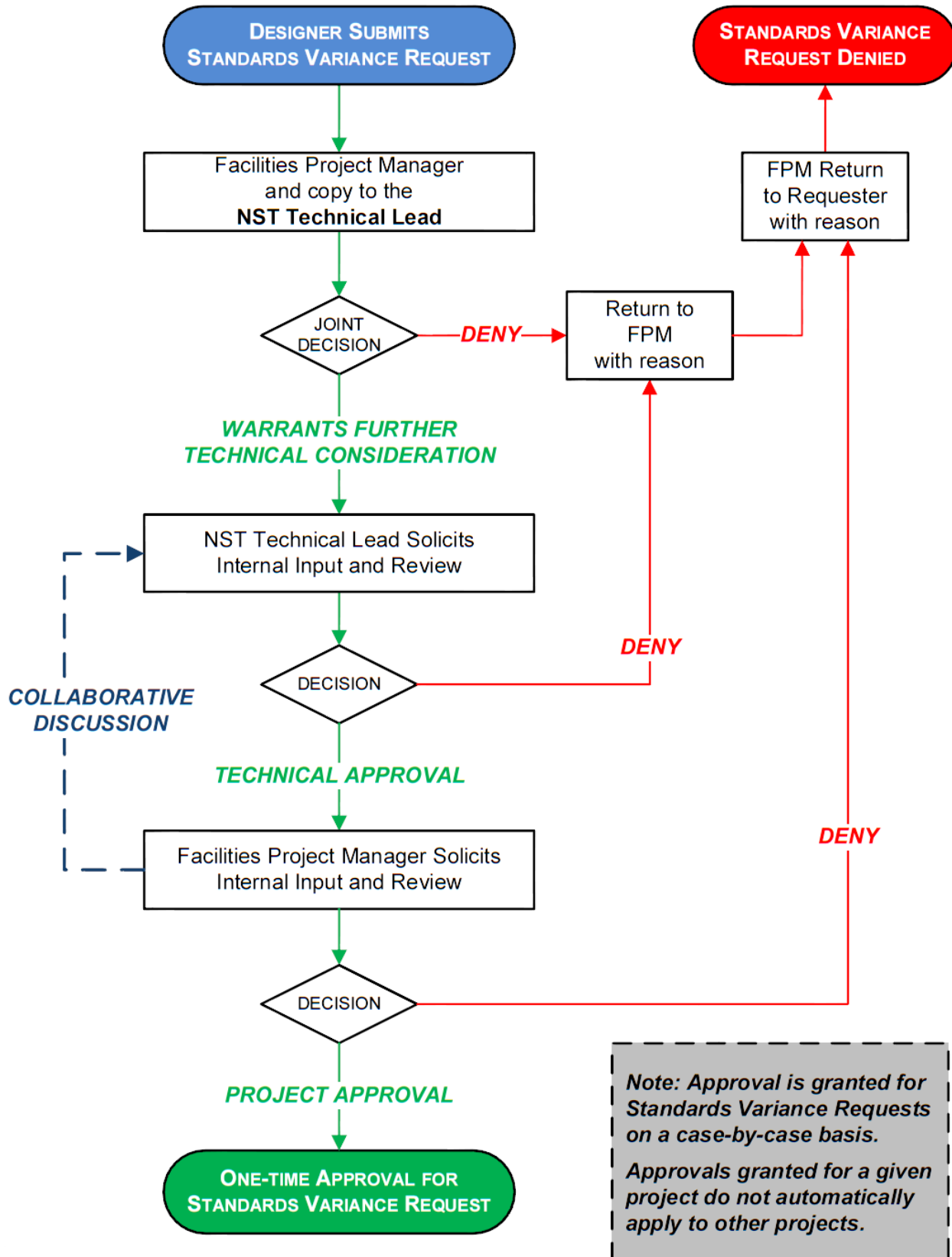

The following form is available in MSWord format for submitting a Standards Variance Request:



STANDARDS VARIANCE REQUEST

November 1, 2018

To: Name of FPM
 Clemson University

From: Name of Telecommunications Designer
 Organization
 Phone #
 Email Address

In accordance with the process described in the Clemson University Telecommunications Distribution Design Guide (paragraph #2.5.3), we are submitting this Standards Variance Request. Please review this request with the NST Technical Lead and let us know whether this will be acceptable on this project.

Standards Variance Request	
Project Name and #	
Reference where existing standard requirement is described	
TDDG Paragraph #	TCGS Section # and Paragraph #
Recap of Existing Standard Requirement	
Description of Proposed Variance	

NETWORK SERVICES & TELECOMMUNICATIONS
120 McGinty Court, Barre Hall Room B-100, Clemson, SC 29634-2809
 Phone (864) 656-9302 - Fax (864) 656-0333

2.6 General Procedures

2.6.1 PROCUREMENT AND INSTALLATION

- A. The Designer shall inquire which procurement method will be used for a particular project. The construction documents prepared by the Designer shall be suited for the procurement method designated for the project.
- B. Typically, the construction contract scope of work includes the complete telecommunications infrastructure (pathways, spaces, cabling and terminations).

The network electronics are usually handled as a separate contract managed by Clemson NST.

2.7 Procedures Related to Project Phases

In addition to the State of South Carolina contract requirements, Designers of technology infrastructure and systems for Clemson facilities have the following responsibilities during each project phase:

2.7.1 PRE-DESIGN

During Pre-Design, the Architect shall involve the Designer to incorporate the following considerations:

- Location and capacity of existing technologies and infrastructure that might be used to support the project.
- Identifying any existing underground infrastructure that might conflict with the footprint of new work.
- Telecommunications room sizes and centralized locations.
- Audio/Visual equipment room sizes and desirable locations.

2.7.2 SCHEMATIC DESIGN AND FIELDWORK

Some projects at Clemson campuses may require the Designer to conduct preliminary fieldwork to document the existing equipment, cabling and applications into which new technology will integrate. Clemson believes that this information is vital to a successful project.

- A. For projects that involve modifications to existing buildings, the Designer shall visit the project site during the Schematic Design phase to perform preliminary field investigation of the horizontal and intra-building backbone telecommunications infrastructure. The Designer shall create the following types of documentation based on information gathered while on site:
 - Take digital photographs of existing pathways, spaces, equipment, and cabling that affect or are affected by the new project work.

- Verify existing or create a new backbone schematic diagram showing the existing outside plant cabling in the area associated with the new project and the existing equipment connection strategy.
- B. The Designer shall also conduct a needs analysis (involving Clemson personnel) to identify and describe the required features and functionality of the new applications.
- C. The information gathered during the fieldwork, combined with the results of the needs analysis, shall be the starting point for Schematic Design of the proposed new work.
- D. The Designer shall discuss pathway type and size options with the Clemson Technical Lead.
- E. Schematic Design drawings shall show the following information:
 - Building and OSP distribution
 - Telecommunications Room sizes and locations
 - Major distribution pathways inside the building, including cable trays
 - Audio/Visual Equipment Room sizes and locations
- F. Upon completion of the Schematic Design documents, the standard Design Review Process shall be conducted prior to progressing to the Design Development phase.

2.7.3 DESIGN DEVELOPMENT

The Designer shall modify the design documents to address the review comments received during the Schematic Design Phase.

- A. In addition to the content shown on the Schematic Design documents, the Design Development documents shall show the following information:
 - Schematic diagrams
 - Device box locations and port (jack) counts for each box
 - Equipment/Device types and locations
 - Draft of specifications based on the Construction Guide Specifications
- B. Upon completion of the Design Development documents, the standard Design Review Process shall be conducted prior to progressing to the Construction Document phase.

2.7.4 CONSTRUCTION DOCUMENTS

The Designer shall modify the design documents to reflect the accepted review comments received during the Design Development Phase.

- A. It is expected that the Designer will expend considerable effort coordinating details between different disciplines during the design process. Non-coordinated pathway/raceway is not acceptable to Clemson.
- In particular, accessible cable tray is crucial to Clemson’s operations. The Designer shall work with the mechanical designers to coordinate ductwork such that it does not obstruct access to the cable tray.
- B. During the Construction Documents phase, the Designer shall obtain the assistance of manufacturer product representatives to review the CGS-based project specifications to determine that the correct part numbers have been included for each product in the specification. The specifications shall be adapted by the Designer from the Clemson Construction Guide Specification.
- C. Upon completion of the Construction Documents, the standard Design Review Process shall be conducted. The Designer shall then modify the documents to reflect the accepted review comments associated with the Construction Documents prior to the Bidding Phase.
- D. The Construction Documents are expected to contain the items discussed in the **Construction Document Content** of each Design Guide.
- E. Upon completion of the Final Construction Documents, the standard Design Review Process shall be again conducted as described above. The Designer shall modify the documents to address the review comments associated with the Final Bid Documents prior to the bidding phase rather than “by addendum.”

2.7.5 BIDDING

On projects where a pre-bid walkthrough is held, the Designer shall attend the walkthrough and shall discuss any materials and practice requirements that the bidders might find peculiar, or which might affect the bids if such requirements were overlooked.

- A. Noteworthy items would typically be requirements that are more restrictive than practices considered acceptable for other commercial projects. The Designer shall consider the following items for inclusion on such a list, as well as any other items applicable to the project:
- The fact that most of the materials specified for use in Clemson’s technology applications are not designated as “or equal, according to the judgment of the contractor.” Any material substitutions must be approved in advance by the Designer in counsel with the Clemson Technical Lead.
 - The requirement that the technology subcontractors must be pre-approved, prior to the bid, and that bids from subcontractors who have not been pre-approved will be considered non-responsive.
 - The fact that Clemson’s technology infrastructure standards and specifications are more stringent than typical electrical installation requirements or the specifications on many other projects.
 - The use of flex-conduit is prohibited.
 - The installation of conduit under-slab or in-slab is prohibited for on-grade

- slabs, except where specifically noted.
 - The requirement for no more than two 90-degree bends in any conduit run.
- B. The Designer shall pay close attention to the addendums produced by other disciplines on the design team, noting any changes that conflict with technology infrastructure. The Designer shall promptly address any such conflicts, bringing them to the Technical Lead's attention in each case.
- C. Approximately ten days prior to the date that bids are due, the Designer shall issue an addendum reiterating the requirement for technology subcontractors to have been pre-approved. The addendum should also list the name and contact information for any subcontractors who have been pre-approved. The objective is that the bidders should receive this finalized list of pre-approved subcontractors not less than one week before the bids are due.
- The Designer, in cooperation with the NSTTL and AVTL, shall together review the pre-qualification request, and make a unified decision to approve or reject the request.

2.7.5.1 DESIGN-BUILD BIDS

On design-build projects where a designer/contractor team will design and then construct the work, the Contractor shall prepare and submit the documentation and content described in Section 4 *Construction Document Content* with their bid, depicting what will be installed by the Contractor.

All drawings shall be prepared using professional design software. Drawings that are hand-drawn sketches or produced using bitmap graphics editors shall not be accepted.

See Section 4 Construction Document Content for additional information.

2.7.6 CONSTRUCTION OBSERVATION

- A. The Designer and the NSTTL shall review the Contractor's submittals that are required by the Construction Documents. When the Contractor's submittals include materials or methods that deviate from Clemson standards, the Designer shall either:
- Reject the specific materials and methods that do not comply, when the Designer believes that they constitute undesirable solutions.
 - Pursue the SVR process to seek separate approval for each specific material and/or method that the Designer believes would constitute a better solution.
- B. The Designer shall visit the construction site frequently to observe the construction quality and status. Prior to proposing services for the project, the Designer shall confer with the Clemson FPM to determine an appropriate site-visit frequency for the project. The site-visit frequency will likely fluctuate during the construction phase as the technology-related activity increases and decreases.

- In particular, the Designer shall observe any rough-in work that will be concealed in walls, or pathways that will be buried or concrete-encased.
- C. The Designer shall invite the NSTTL to attend a construction observation meeting prior to the pouring of concrete to allow Clemson NST to check the pathways that will then become concealed.
- D. During all site visits, the Designer shall take digital photographs of existing and new pathways, spaces, and cabling – both intra-building and outside plant – that are related to the project. In particular, the Designer shall photograph infrastructure that will later be concealed during the course of construction.
- E. It is the responsibility of the Designer to verify that the Contractor properly labels all cabling in a manner consistent with Clemson standard labeling practices (both inside plant and outside plant) during construction. Inadequate or incomplete labeling is not acceptable.
- F. Accurate as-built drawings are considered critical for the efficient long-term operation of Clemson facilities. During construction observation visits, the Designer shall observe and report on the Contractor’s progress toward staying current with the as-built drawing notations.
- G. After each construction observation visit, the Designer shall submit a written report describing the observed construction progress. Observations shall be documented in the report with annotated digital photographs and a written description of any problems, a description of the requirements in the Construction Documents, and the resolution to the issues. For each item requiring corrective attention, the report shall describe the following:
 - A description of the issue
 - Applicable requirements in the Construction Documents
 - Applicable Clemson standards, industry standards, and codes
 - Corrective options available to Clemson
 - Designer’s recommendation
- H. The Designer shall submit the construction observation reports via email to the Clemson FPM and the Clemson Technical Lead as soon as possible following each site visit. The reports shall also be reviewed at the next construction meeting. A timely report submission will aid the Designer and Clemson in identifying potential problems early in the construction process.
- I. The Designer shall alert the Contractor that cable testing shall be performed after electrical systems have been powered on and after building operational conditions become similar to normal operations. Also, any dust-producing construction activities shall be completed prior to any cable testing. The intent is that testing not be done until normal operating conditions exist (and the associated EMI is being generated by electrical systems in the building).

2.7.6.1 PLUMBING AND PIPING

Verify that water piping, including fire suppression piping, does not pass through any telecommunications rooms (except for chilled water supply to the fan coil unit or fire suppression system serving the room).

Verify that condensate lines associated with telecommunications room air conditioning equipment routes in a manner that avoids conflict with telecommunications features.

2.7.6.2 CABLE TRAYS

Verify that the installed cable trays meet the following requirements:

- A. Wherever cable tray passes through a wall, the wall penetration shall be finished (no sheetrock visible) and firestopped using STI EZ-Path if the wall is a fire-rated wall.
- B. To protect technicians and cabling, all cuts to cable tray materials shall be finished smooth. Cable trays shall not have rough or sharp edges or points.
- C. Each segment of the cable tray requires a ground conductor bonding lug.
- D. When cable trays, walls and ceilings are painted, care shall be taken to not paint the cabling. Cable manufacturers will not warrant any painted cabling. Also, paint obscures the manufacturer-printed labeling on cables.

2.7.7 POST-CONSTRUCTION

- A. The Designer shall review the Operation and Maintenance information provided by the Contractor for the telecommunications distribution system. The Designer shall verify that information is included for each component in the system. Upon approval of the content in the Operation and Maintenance information, the Designer shall submit the information to the designated Clemson Technical Lead with written documentation indicating that the Designer has reviewed the information and that it appears to meet the requirements in the Construction Documents.
- B. The Designer shall provide record drawings and record documentation to Clemson (based on as-built documents that have been “red-lined” by the Contractor). Record documents shall be provided in electronic CAD format where applicable, in addition to requirements put forth by the Designer’s contract with Clemson.
- C. The Designer shall review the test reports produced by the Contractor during the project. The Designer shall verify that the test reports are complete, properly performed, and indicate passing results.
- D. The Designer shall verify that the Contractor provides the appropriate manufacturer’s warranty certification documentation to Clemson.

2.8 Designing for Demolition

Some projects may involve existing buildings that require the demolition of existing telecommunications cabling and components. In these situations, the following activities are required:

2.8.1 SITE-SPECIFIC CODE REQUIREMENTS

The Designer shall clearly understand the site-specific, Code-based requirements for demolishing cabling and components that are no longer in use, and shall communicate these requirements to Clemson.

- Generally, this means that all abandoned cabling shall be removed during demolition or after cutover.

2.8.2 PRESERVATION OBJECTIVES

Clemson may wish to preserve some existing cables in operational condition. Such existing cables may not be used immediately following the completion of the work, but Clemson may have plans for future use of those cables. It may be required in the Code that such cables be physically tagged for future use, or otherwise be subject to demolition.

The Designer shall inquire with Clemson on a project-by-project basis about cabling, equipment, and other materials that should be preserved in an operational condition during the course of a project.

2.8.3 SALVAGE OBJECTIVES

The Designer shall inquire with Clemson on a project-by-project basis about cabling, equipment and other materials that should be removed and salvaged to the Owner, and also to determine how and where the salvaged materials will be delivered to the Owner.

3 Design Criteria

The Clemson TDDG is not intended to be a comprehensive design guide resource for telecommunications design at Clemson facilities. The Designer shall refer primarily to the BICSI TDMM for design guidance. The Construction Documents produced for each project shall be consistent with the installation practices described in the BICSI Information Transport Systems Installation Methods Manual (ITSIMM).

- A. Where ANSI/TIA/EIA standards or BICSI manuals offer multiple choices with a preferred method identified, and where the Clemson TDDG does not select one method over another or define specific requirements precluding use of the preferred method, the ANSI/TIA/EIA or BICSI-preferred method shall be selected.
- B. Where ANSI/TIA/EIA Standards or BICSI manuals identify warnings regarding potential adverse effects from certain design or installation methods, the design or installation method used shall typically be the method with the least potential for adverse effects. The Designer shall notify the NSTTL of any such decisions.
- C. Any request to deviate from the requirements of the National Electrical Code or the manufacturer's warranties will not be accepted. The Designer shall seek approval for designs that are not consistent with Clemson TDDG requirements through the Clemson Standards Variance Request (SVR) process. Requests to deviate from industry standards or Clemson design solutions will be considered on a case-by-case basis by the NSTTL. Designers may contact the NSTTL to discuss proposed alternatives before spending significant time researching or preparing an SVR.
- D. Telecommunications distribution infrastructure shall fully comply with the current Clemson TDDG, the current ANSI/TIA/EIA Commercial Building Telecommunications Standards, and the National Electrical Code (NEC).
- E. Please refer to the *Bibliography and Resources* section and *Glossary* section of the BICSI TDMM for definitions, abbreviations, acronyms, and symbols used for describing and documenting telecommunications infrastructure at Clemson facilities.
- F. The following subsections are arranged to mirror the chapter sequence of the BICSI TDMM 14th Edition (the subsection numbers below are in the form of "4.x" where x corresponds with the chapter number in the BICSI TDMM).
 - Each TDDG subsection contains commentary and requirements regarding the application of the BICSI TDMM to Clemson projects. In particular, each section contains limitations and prohibitions on specific materials and methods discussed in the BICSI TDMM.

3.1 Principles of Transmission

Please refer to Chapter 1, *Principles of Transmission* in the BICSI TDMM for general information regarding the design of telecommunications distribution infrastructure.

3.2 Electromagnetic Compatibility

Please refer to Chapter 2, *Electromagnetic Compatibility* in the BICSI TDMM for general information regarding EMI and clearance requirements for telecommunications infrastructure. The following requirements take precedence over the BICSI TDMM guidelines for telecommunications infrastructure at Clemson facilities:

- A. The BICSI TDMM includes tables listing minimum separation distances from sources of EMI. Telecommunications infrastructure shall not be installed closer than the minimum separation distances listed in the BICSI TDMM. Where the NEC or local codes require greater separation distances than those listed in the BICSI TDMM, the greater separation distance shall be maintained.
- B. Separation distances apply equally to both copper cabling and fiber optic cabling. Even though fiber optic cabling is impervious to EMI, once a pathway is established for fiber, it could later be used for copper cabling.
- C. OSP telecommunications infrastructure designs shall adhere to the governing clearance requirements of the NEC and NESC.

3.3 Telecommunications Spaces

Please refer to Chapter 3, *Telecommunications Spaces* in the BICSI TDMM for general information regarding the design of telecommunications rooms (TR). The following terms are used somewhat interchangeably when referring to TRs:

- “MDF”, meaning “main distribution frame,” is a legacy term for the main telecommunications room and entrance facility in a building. The word “frame” is a legacy term for a telecommunications rack.
 - “IDF”, meaning “intermediate distribution frame,” is a legacy term for all other telecommunications rooms in a building that are not the main TR, and therefore subordinate to the main TR.
- A. In Clemson facilities, the TRs in a building serve as low-voltage systems equipment rooms for the building network, typically containing electronic equipment intended to serve the building or a portion of the building.
 - B. Fire alarm control panels (FACP) shall not be mounted in telecommunications rooms.
 - C. TRs shall not be shared with electrical installations, other utilities, access control panels, custodial, facilities management or used for storage. Rather, the MDF and IDFs should be spaces dedicated for **CCIT systems use only**.

The following requirements take precedence over the BICSI TDMM guidelines for telecommunications infrastructure at Clemson facilities:

3.3.1 TELECOMMUNICATIONS ROOM LOCATION

- A. The Designer shall be responsible to inform the Architect of the sizing and location requirements for Telecommunications Rooms during the Schematic Design phase of the project.
- B. The most desirable location for telecommunications rooms shall be as central and close as possible to the area being served. In addition, for multi-story buildings, telecommunications spaces shall be vertically aligned. This allows for the easy provision of clean, vertical pathway to each space. It also reduces the number of bends and offsets that the intra-building backbone pathway must undergo as it connects each of the telecommunications rooms. Please see the discussion in TDDG Section 3.4.1 *Intra-building Backbone Pathways* for additional information.
- C. There shall be a minimum of one TR per building. Additional TRs shall be added when the area to be served exceeds 10,000 square feet or where the cable lengths will exceed 295 feet between a TR and the work area telecommunications outlet, including allowance for cable slack loops. Generally, each floor of a building shall be served by a TR located on that floor.
 - When specifically approved by the NSTTL, a TR may be designed to serve multiple floors of a building.
- D. Telecommunications Rooms shall not be co-located with any type of electrical room or mechanical room. The TR location shall maintain the separation distances identified in the Electromagnetic Compatibility subsection of this document.
- E. The telecommunications room shall not be located in any of the locations listed below:
 - Areas subject to water or steam infiltration, particularly basements. Floor drains (with deep traps and/or other method to prevent backflow and entry of gases) are required if there is any risk of water entry. Do not use trap primers.
 - Areas exposed to excessive heat or direct sunlight.
 - Areas exposed to corrosive atmospheric or environmental conditions.
 - Near or adjacent to potential sources of EMI or radio frequency interference (RFI) such as large electric motors, power transformers, arc welding equipment, or high-power radio transmitting antennas.
 - In a shared space with electrical equipment other than equipment serving the telecommunications system.
 - Areas should not have windows or secondary entrances.
 - Areas should not be located under or adjacent to rooms that would require plumbing or cleanouts to be located in the telecommunications room.

3.3.2 TELECOMMUNICATIONS ROOM SIZING

- A. Telecommunications rooms shall typically be one of the following sizes in the table below (or larger where required):

TR Dimensions	# of Racks	Design Limitations Day 1/Future (Full)	Comments
15' x 10'	4	720/960 CAT6A Cables	
12' 6" x 10'	3	528/768 CAT6A Cables	Standard IDF/MDF
10' x 10'	2	320/480 CAT6A Cables	Only when specifically approved by the NSTTL

Please note that the above room sizes are minimum interior dimensions, and are not representative of acceptable square footage allocations.

- For example, a 12' 6" x 10' space totals 125 square feet. A 25' x 5' room would be an unacceptable space, even though it also totals 125 square feet.
- Telecommunications rooms shall be rectangular. Unconventional shapes are not acceptable.
- All room dimensions listed in this document are interior-clear dimensions, independent of the thickness of the walls.

See the sample telecommunications room plan drawings in Appendix 5.3 of the TDDG for additional information.

- B. The 10' dimension is derived from the following space allocation requirement:

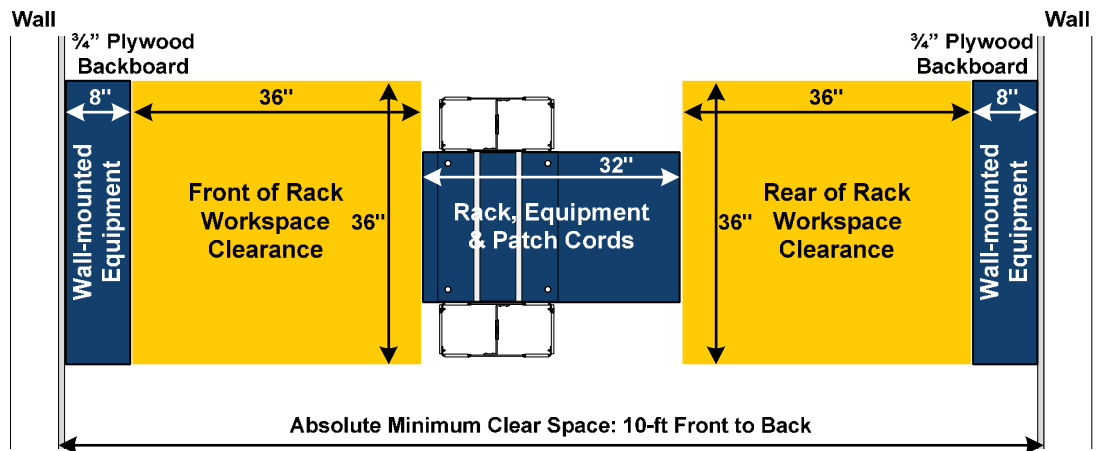

- C. If project circumstances prevent the establishment of adequately sized telecommunications spaces, the following options may be considered on a case-by-case basis, subject to the approval of the NSTTL:

- Reach-in closets and small room designs for minor remodel construction projects may be considered through the SVR process.
- Wall-mounted swing cabinets may be appropriate for some remodel applications serving small numbers of people and where floor space for a full telecommunications room would be unavailable or impractical.

- D. Telecommunications room sizing shall be increased if other low-voltage systems equipment (such as security system equipment) is intended to be hosted in the TR. The Designer shall seek input from the NSTTL regarding room sizing.
- E. Telecommunications rooms in new construction and modernization projects shall be sized such that ADA-required space is available after racks and equipment have been installed.

3.3.3 ARCHITECTURAL PROVISIONING

- A. The Designer shall be responsible to inform the Architect early in the Design Development phase of the project of the architectural provisioning requirements for Telecommunications Rooms.
- B. The Designer shall be responsible to review project documents and determine that the architectural requirements for the telecommunications spaces are met as described in this document. For projects where an Architect is involved, the Designer shall coordinate directly with the Architect, and verify that the Architect's design documentation meets these requirements. For projects without an Architect, the Designer shall alert Clemson where additional architectural adjustments are needed to meet the requirements.
- C. Doors shall open out from telecommunications spaces and shall be a minimum of 36" wide and 80" high, fitted with a strike cover, lock, and electronic access control. Wherever possible, doors shall have a 180-degree swing. Coordinate lock and key requirements with Clemson. Doors shall be located in hallways or other common areas. Telecommunications room doors shall never be located in another building occupant's designated space.
- D. Minimum clearance height within a telecommunications space shall be 9 feet. False ceilings (t-bar ceilings, ceiling grids, etc.) shall not be installed in telecommunications spaces. The floor, walls, and ceiling shall be sealed to reduce dust.
- E. Finishes shall be white to enhance room lighting. Flooring materials shall be light colored and slip-resistant; carpet is not acceptable for telecommunications rooms. Interior floor finish and floor covering materials shall also meet the requirements in the International Building Code.

3.3.3.1 PLYWOOD BACKBOARDS

- A. The walls in telecommunications rooms shall be covered with painted, fire-treated plywood backboards.
- B. Plywood backboards shall be constructed as follows:
 - Use $\frac{3}{4}$ " void free A-C or better plywood that has been treated with fire retardant chemicals by a pressure impregnation process. Mount A side exposed with stamping (1 stamp per board) left visible after painting.

- Plywood backboards shall extend from 6" above finished floor up to a height of 8'6" above the finished floor.
- Paint the plywood first with primer followed by a minimum of two coats of **white** paint.
- All painting shall be completed prior to the installation of telecommunications equipment.

3.3.4 ENVIRONMENTAL PROVISIONING

- A. Environmentally friendly solutions shall be considered in the design of cooling systems for technology spaces, incorporating heat reclamation and non-mechanical cooling features where reasonable and practical.
- B. The Designer shall be responsible to inform the Mechanical Engineer early in the Design Development phase of the project of the environmental provisioning requirements for Telecommunications Rooms.
- C. The Designer shall be responsible to determine that the mechanical HVAC requirements for the telecommunications spaces are met as described in this document. For projects where a Mechanical Engineer is involved, the Designer shall coordinate directly with the engineer, and verify that the engineer's design documentation meets these requirements. For projects without the involvement of a Mechanical Engineer, the Designer shall alert Clemson where adjustments to the mechanical infrastructure are needed to meet the requirements.
- D. The Designer shall coordinate with the Mechanical Engineer to ensure that the HVAC requirements for the telecommunications spaces are met and also that HVAC ductwork and motors do not conflict with cable tray or conduit routing.
 - Minimum clearance height in the TR shall be nine feet without obstructions (light fixtures, ducting, etc.).
- E. In addition to the requirements in the BICSI TDMM, telecommunications rooms shall be environmentally provisioned as follows:
 - A fundamental design assumption is that all TRs will at some time contain active electronic equipment (hubs, routers, switches, etc.) even if the current design does not call for such devices. Network electronics require an HVAC system capable of operating on a 24/7/365 basis. If the building system cannot assure continuous cooling operation, a stand-alone cooling unit shall be provided for the TR.
 - This unit and any roof penetrations shall be located away from and not directly above electronics of any kind, to avoid damage from condensate drip and roof leaks.

In addition, a positive pressure differential with respect to surrounding areas is required to help keep dust and other particles out of the room.

- Where practical, Clemson encourages the use of heat reclamation features.
 - Environmental management and monitoring systems shall be designed for TRs.
 - Year-round cooling is required for telecommunications rooms. Where chilled water service is available (typically for on-campus buildings) Use wall-mounted fan coil units that take advantage of the chilled water system. Otherwise, wall mount split systems are the required solution. The mechanical designer shall inquire with the FPM about which cooling solution should be used for a given project.
 - The temperature controls (including a thermostat) shall be located inside the telecommunications rooms and connected to the building environmental control system. Alarm conditions shall be configured to alert both NST and Facilities personnel.
 - Positive pressure must be maintained in the space to prevent the collection of dust.
- Clemson typically provides network electronics that provide Power-over-Ethernet. The Designer shall request power consumption data for the equipment that Clemson will use, and work with the mechanical systems designer to ensure that the cooling capacity is sufficient to support the POE heat load.

3.3.5 PLUMBING

Water piping shall not pass through telecommunications rooms unless it is serving the telecommunications room in the capacity of fire suppression or cooling. The Designer shall coordinate with the mechanical/plumbing designer to route piping around telecommunications rooms.

3.3.6 FIRE SUPPRESSION SYSTEMS

Clemson requires fire suppression sprinklers in all telecommunications rooms, without exception.

- The Designer shall coordinate with the designer of the building's fire suppression system to ensure that wherever possible sprinkler heads are located above walking spaces in telecommunications rooms, rather than above racks where inadvertent leaks or drips could damage equipment.
- The Designer shall coordinate with the designer of the building's fire alarm system to ensure that smoke detectors are designed for telecommunications rooms.
- Cages are required for sprinkler heads in telecommunications rooms.

3.3.7 CABLE TRAY ENTRANCE

- A. Horizontal cabling shall be routed into telecommunications rooms via cable tray

entrance slots permitting the tray to pass through the walls, protruding 2” into the room. Cable trays shall terminate above the ladder racking in the telecommunications rooms and have a radius fitting (“waterfall”) to protect the cabling as it drops to the ladder rack. Where cable trays pass through fire-rated walls to enter the telecommunications room, the design shall include STI EzPath sleeves.

- B. See Section 3.7 *Firestop Systems* for requirements for treating fire-rated walls through which cable trays pass.
- C. The Designer shall design cable trays and entrance slots. Conduit entrances are also permitted; however, cable tray is preferred.

TR Dimensions	# of Racks	# of 12"x4" Cable Tray Entrances Required (or the equivalent conduit cross-sectional area)	
15' x 10'	4	Four 12"x4" slots	Fourteen 4" conduits
12' 6" x 10'	3	Three 12"x4" slots	Eleven 4" conduits
10' x 10'	2	Two 12"x4" slots	Seven 4" conduits

- D. See Appendix 5.3 for examples of cable tray entrance slots.
- E. See Appendix 5.2 for rack elevation samples indicating the total number of cables allowable for Day 1, and also showing the additional future 48-port patch panels that the racks could support if necessary.

3.3.8 FLOOR-STANDING EQUIPMENT RACKS AND CABINETS

- A. Each telecommunications room shall be provisioned with a full set of floor-standing 7' high x 19" wide ANSI/TIA/EIA standard open-frame equipment racks to fill the room, regardless of whether or not equipment is required at the time of construction.
 - The use of alternative equipment mounting systems may be acceptable, subject to Clemson approval via the SVR process.
- B. The rack arrangement shall be selected from the options shown in Appendix 5.2, and shall be sized to accommodate, at a minimum, all existing and new equipment that is to be installed in the rack plus space for additional equipment that may be added in the future.

3.3.8.1 EQUIPMENT RACKS

- A. See the sample floor plan details in Appendix 5.3 of the TDDG for rack arrangement guidance.
- B. Floor-standing racks shall be securely bolted to the floor, and shall be braced to the wall with cable ladder racking. Multiple racks in the same TR shall be interconnected with cable ladder racks.
- C. Racks shall be equipped with horizontal cable lacing bars and vertical cable

management modules both front and rear, with strain relief brackets to support proper cable bend radius and to maintain strain relief for the cabling. Vertical cable management modules shall include spools/posts to manage cable slack.

- Vertical cable management between racks shall be 12” wide. Some applications, however, may require 15” wide vertical cable management between racks.
 - Vertical cable management on both ends of the row of racks shall typically be 10” wide. Some applications, however, may require 12” wide vertical cable management on the ends of the row.
 - In addition, 4” wide single-sided vertical cable management shall be provided in specifically indicated locations for the purpose of mounting power outlets. See the sample floor plan details in Appendix 5.3 of the TDDG showing where the 4” cable management shall be provided.
- D. Sometimes an equipment cabinet is required for larger IT equipment (servers, large UPSs, etc.) with both front and rear mounting rails. The Designer shall discuss with Clemson the network electronics that will be hosted in each TR and shall design appropriate racks and cabinets to support the equipment. Racks and cabinets shall be shown on the rack elevation details in the plan drawings.
- E. Ladder racking shall be provided at 7 feet 6 inches above finished floor, as shown in Appendix 5.3. The ladder racking shall be 18” wide circling the room and 12” wide to connect the equipment racks.

3.3.8.2 TELECOMMUNICATIONS CABINETS

- A. When planning the size and location of TRs in existing buildings, the Designer shall make every reasonable effort to meet the requirements for telecommunications rooms. In certain instances, the only viable alternative may be the use of one or several telecommunications cabinets in lieu of TRs.
- B. In minor remodel projects, some buildings may not justify a separate room as the telecommunications room. In some circumstances, sufficient space may not be available for a telecommunications room. In these instances, a wall-mounted or floor-standing telecommunications cabinet may be used.
- C. Wall-mounted cabinets shall be double-hinged to permit access to both the front and rear of the equipment. Care shall be taken to specify cabinets with strong hinges that do not begin to sag over time due to the weight of the cabinet’s contents. Telecommunications cabinets shall be constructed of heavy gauge steel with lockable doors.
- D. Cabinets shall be sized to allocate space for cabling termination infrastructure, network electronics, and UPS equipment, and shall also include space allocated for future growth. Adjacent wall space shall be allocated to permit cabinets to fully swing open.

- E. Cabinets shall be equipped with horizontal wire management modules with strain relief brackets to support proper cable bend radius and to maintain strain relief for the cabling.
- F. Power and telecommunications cables for equipment housed within the cabinet are to be contained within the cabinet. Exposed wiring or cables are not permitted. Power and telecommunications cables routed to or from the cabinet shall be contained in conduit, in surface-mounted raceway, or concealed within the adjacent wall.
 - Technical power outlets serving cabinets shall be mounted inside the cabinet.
- G. Each cabinet that hosts equipment that produces a significant heat load shall have front and rear screen doors, allowing air-flow through the equipment. Cooling fans are required.
- H. Each cabinet shall have a telecommunications grounding busbar (TGB) installed inside, in accordance with the grounding requirements discussed in the BICSI TDMM Chapter 8 *Bonding and Grounding (Earthing)*.
- I. The cabinet shall not be located in or adjacent to areas containing sources of EMI. See TDDG Section 3.2 *Electromagnetic Compatibility* (above) for additional information.

3.3.9 POWER REQUIREMENTS

- A. The Designer shall be responsible to determine that the power requirements for the telecommunications spaces are met as described in this document. For projects where an electrical engineer is involved, the Designer shall coordinate directly with the engineer, and verify that the engineer's design documentation meets these requirements. For projects without the involvement of an electrical engineer, the Designer shall alert Clemson where additional power infrastructure is needed to meet the requirements.
- B. Clemson typically provides network electronics that provide Power-over-Ethernet. The Designer shall request power consumption data for the equipment that Clemson will use, and work with the electrical power distribution designer to ensure that the cooling capacity is sufficient to support the POE heat load.
- C. As a State institution, Clemson University is authorized by the State to employ qualified individuals who serve the role of the "Authority Having Jurisdiction" (AHJ). The Designer shall anticipate communicating and cooperating with Clemson's electrical AHJ representatives on Clemson's projects.

3.3.9.1 BACKUP POWER (GENERATOR & UPS)

Clemson typically does not provide backup power for technology applications unless the application falls under one of the two following categories:

3.3.9.1.1 LIFE-SAFETY SYSTEMS (NEC 700.1)

- A. Clemson University has designated the following two pieces of technology equipment as life-safety systems, both of which are typically located in the MDF:
- The network router for the building
 - Analog telephone gateways and the network switch to which they are connected

The Designer shall inquire with the FPM and the NSTTL whether a project includes any additional systems that have been designated as life-safety systems

The Designer shall also inquire with the FPM and the NSTTL whether a project includes any other building systems that rely upon network switches for their operation.

- VOIP telephones are normally not considered to be life-safety devices. However, in some special facilities such as the fire station and police station, the telephone system may be designated as such.
- B. The Designer shall meet with the FPM and the NSTTL and have a detailed discussion about any low-voltage systems that are designated to be life-safety systems, and how Clemson would prefer to provide backup power to these systems.
- C. Life-safety systems must be kept operational for a minimum of 90 minutes after utility power is lost.
- D. Options for providing emergency backup power include uninterruptible power supply (UPS) equipment and generators:
- Where no generator is used, a UPS shall be provided with a minimum runtime of 90 minutes.
 - Where a generator is provided, a UPS shall also be provided having a minimum runtime of 20 minutes. The generator shall have a fuel supply capacity to keep it running at least 90 minutes.
 - The Designer shall discuss with the NSTTL and the FPM what the actual runtime design parameters shall be for a given project.
- E. Most UPS solutions will be rack-mounted (as opposed to centralized UPS equipment).
- F. Generators, UPS equipment, and the associated electrical power distribution systems serving life-safety applications shall be designed by a professional electrical engineer and shall be compliant with NEC 700.1 Emergency Systems.
- G. Power outlets derived from panels and circuits that are supported by emergency backup generators shall be visibly identifiable as such.

3.3.9.1.2 OPERATIONALLY CRITICAL SYSTEMS (NEC 702.2)

- A. Some services are considered essential to the smooth operation of the University and therefore Clemson wishes to keep them operational during a utility power interruption.
- B. The Designer shall inquire with the NSTTL and the FPM whether a given project includes any aspects that Clemson wishes to protect against power outage, and if so, the minimum runtime requirements.
- C. Options for providing backup power include uninterruptible power supply (UPS) equipment and generators.
 - Generators serving applications that are not essential to maintain life are referred to in NEC 702.2 as Optional Standby Systems.
 - Providing generator-backed power is expensive. Be aware that generator systems providing emergency backup power to life-safety systems are not permitted to directly support non-life-safety loads. Instead, a separate electrical power distribution is required for Optional Standby applications.
 - If circumstances are such that an existing Optional Standby generator is available and has capacity for additional load, CCIT NST desires that consideration be given to take advantage of the opportunity to support telecommunications loads. However, CCIT NST typically does not wish to add generators where they do not otherwise already exist.
- D. Most UPS solutions will be rack-mounted (as opposed to centralized UPS equipment).
 - Centralized UPS equipment is primarily reserved for data center-class spaces. The Designer shall inquire with Clemson on a project-by-project basis whether a centralized UPS is desired for the project.
- E. The Designer shall work with the Electrical Engineer to design appropriate power receptacles that will be suitable to serve the Owner-provided UPS equipment that will be used on the project.
- F. The Designer shall reserve sufficient space at the base of an equipment rack in each telecommunications room to hold the Owner-provided UPS equipment.

3.3.9.2 ELECTRICAL POWER PANELS

- A. The technical power circuits in each telecommunications room shall originate from a dedicated telecommunications-specific electrical power panel located **inside** of the telecommunications room. In the absence of other influencing circumstances, the panel shall be sized for 100 Amp service (minimum). The panel shall not be used to supply power to sources of EMI such as large electric motors, arc welding, or industrial equipment.
- B. Technical power power panels shall be equipped with a transient voltage surge suppressor (TVSS) to protect equipment from damage due to power anomalies.

- C. Where possible, it is desirable to strategically assign pairs of similar power outlets serving a given rack to different electrical phases. For example, if a rack has two 120VAC power outlets, wiring each of the two outlets to different circuits on different phases will allow equipment with dual power supplies to continue operating if one of the electrical phases (“legs”) fails.
- D. Care should be taken when preparing panel schedules for technical power panels to describe accurately (in a meaningful way) each outlet in a telecom room and the specific application that it serves (such as “TR 0W – Rack 1 120VAC Quad”) rather than generalized comments that the outlet is located in a specific room.
- E. The following diagram depicts Clemson’s strategy for distributing technical power to telecommunications rooms, with UPS equipment distributed to each telecommunications room:

POWER AND GROUNDING FOR TELECOMMUNICATIONS ROOMS WITH DISTRIBUTED UPS EQUIPMENT

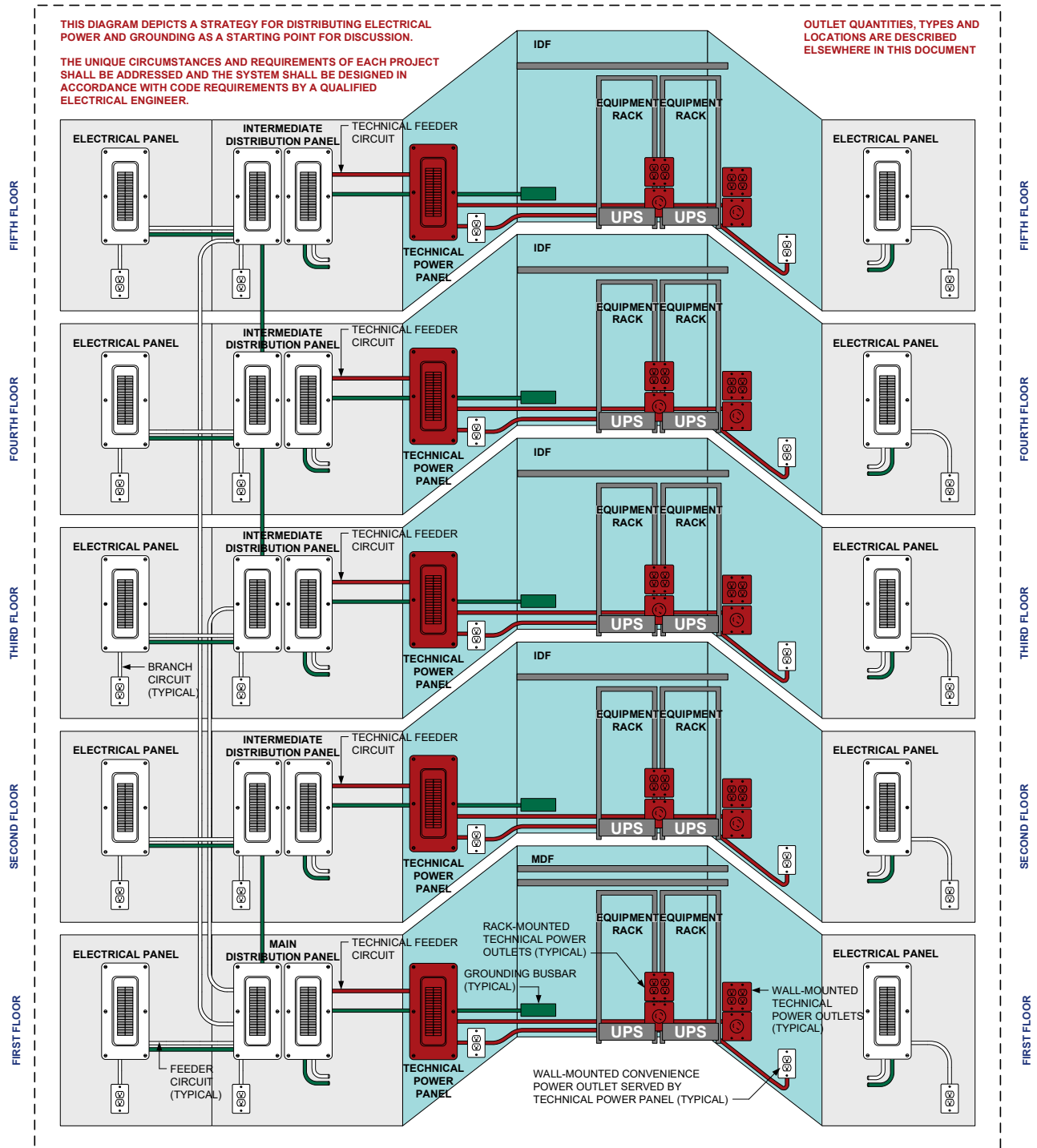

3.3.9.3 TECHNICAL POWER OUTLETS

- A. The Designer shall obtain electrical power connection/load requirements from NSTTL for each piece of equipment, and tabulate the information for review and confirmation by Clemson. This equipment may include network electronics, UPS equipment, computers/servers, phone system equipment, voice mail systems, video equipment, and service provider equipment.
- B. Clemson intends to provide UPS equipment for each telecommunications room that requires unconditioned utility power sources of 208VAC 20A, 208VAC 30A and/or 120V 20A.

The Owner-provided UPS equipment will have 120VAC outlets to meet the needs of the Owner-provided network equipment, and may connect to power distribution units (PDU) supporting rack-mounted equipment.

The diagram below depicts the required power architecture:

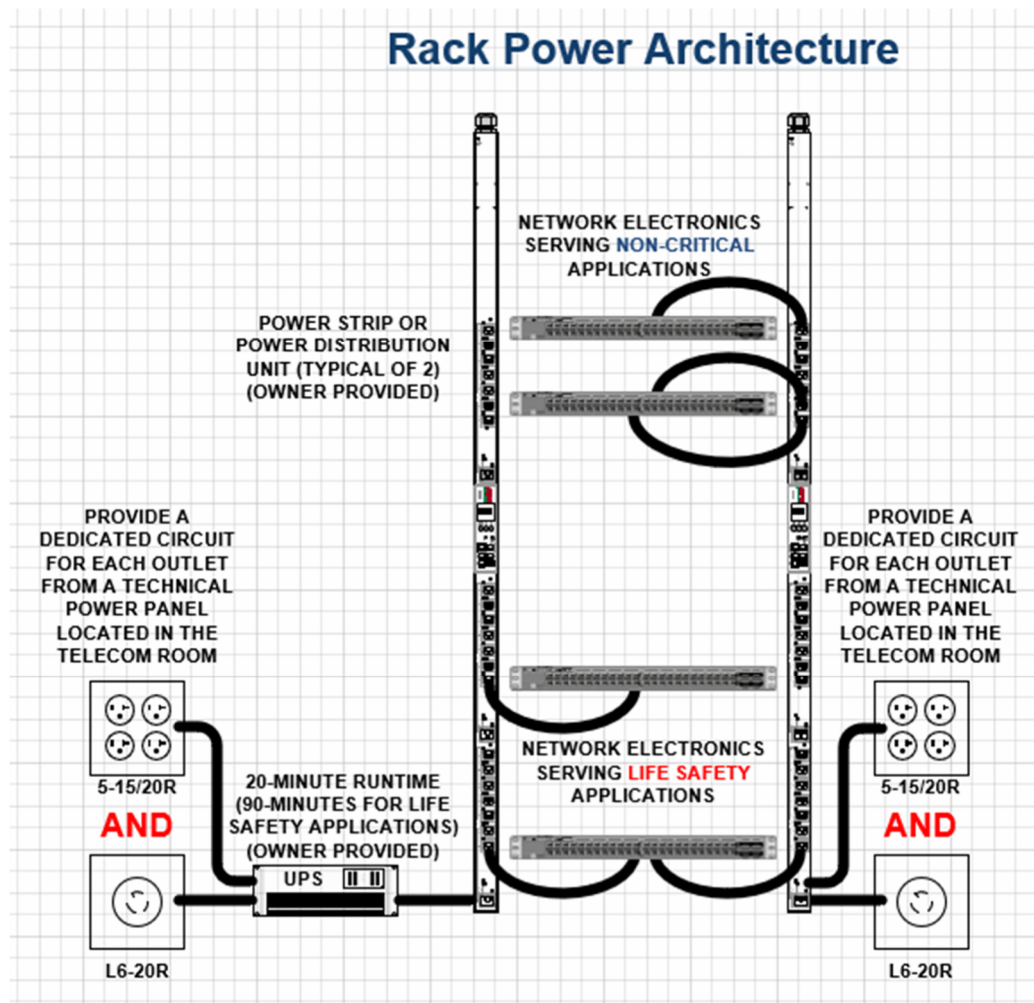

- C. The Designer shall inquire with the NSTTL to determine the voltage, outlet, and circuit requirements for the equipment to be served. Some telecommunications rooms may need both 20A and 30A outlets, whereas other smaller rooms may not need 30A outlets. See the sample telecommunications room plan details in Appendix 5.3 below for outlet types, quantities, and locations. Adjust these outlets after consulting with the NSTTL about the specific needs of a given project while factoring in the possibility of additional future equipment.
- Where 120VAC technical power outlets are required, outlets shall be equipped for “straight-blade plugs” (NEMA 5-15/20R), rather than twist-lock style receptacles.
 - Some UPS and network switch equipment requires specialized plugs or electrical service. The Designer shall inquire with the NSTTL to determine whether any dedicated or specialized circuit requirements exist.
 - Each outlet shall be equipped with a dedicated insulated copper equipment-grounding conductor. Ground conductors serving technical power outlets shall **not** be *isolated* ground conductors.
 - Wall-mounted convenience power outlets (flush-mounted) shall be provided as shown in the sample floor plan details in Appendix 5.3 of the TDDG. Conduits for wall-mounted convenience power outlets shall be installed concealed inside the wall. Surface mounted conduits and boxes are not acceptable.
 - Technical power outlets shall be mounted between racks on 4” wide vertical cable management. See the sample floor plan details in Appendix 5.3 of the TDDG for technical power outlet locations.
 - Single-sided 4” wide vertical cable management shall be installed with the cable management fingers facing the rear of the rack.
 - Technical power outlets shall be mounted on the front side of the rack, attached to the back side of the 4” wide vertical cable management. Conduits between the technical power panel and the technical power outlets shall be routed from above.
 - The following diagrams depict the technical power outlet arrangements for 2-rack, 3-rack and 4-rack applications:

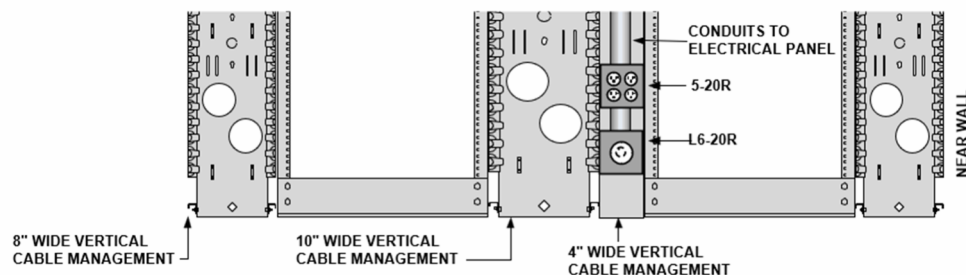

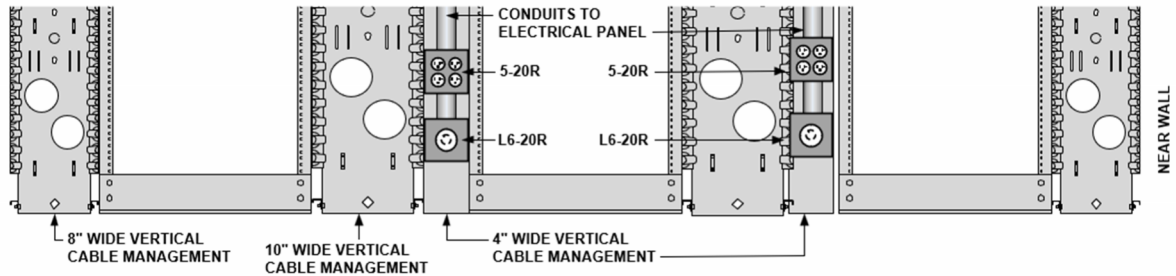

3.3.9.3.1 FOR NEW CONSTRUCTION AND MODERNIZATION PROJECTS

- A. Faceplates for power receptacles and light switches in the TR shall be mounted at the surface of the plywood backboard (as opposed to being recessed into a cutout in the plywood backboard). The device boxes shall be recessed into the wall, and the conduits shall be concealed in the wall (not surface-mounted).
- B. Conduits serving convenience power outlets shall be concealed in walls behind backboards.
- C. In addition to the outlets intended to serve the racks, a minimum of one duplex technical power outlet shall be provided per wall (centered on the wall) except for the wall adjacent to the racks. For walls more than 10' in length, a minimum of 2 outlets shall be provided, and at intervals of no more than 6 feet between outlets.

3.3.9.3.2 FOR MINOR REMODEL PROJECTS

Where telecommunications backboards are applied to existing walls with existing power outlets and light switches, the design shall require backboards to be provided with cutouts permitting access to the existing electrical devices.

New power outlets and conduits might need to be surface-mounted if existing wall construction prevents routing within the wall structure.

3.3.9.3.3 FOR REMODEL PROJECTS

Some existing buildings may have limited capacity in the electrical panels for new power outlets. The Designer shall endeavor to design a solution that is compliant with the requirements in the TDDG for all projects. However, the Designer shall discuss with the FPM and the NSTTL the possibility that existing constraints may affect the scope of the design. The Designer shall coordinate closely with the NSTTL to ensure that the design will meet the operational needs of each application.

3.3.9.4 CONVENIENCE POWER OUTLETS

Convenience power outlets shall be served from the same electrical power panel supplying power to the technical power outlets. Convenience power outlets shall be provided on telecommunications room walls for use with power tools and other non-

technical devices. Conduits serving convenience power outlets shall be concealed in walls behind backboards.

3.3.10 GROUNDING, BONDING, AND ELECTRICAL PROTECTION

All equipment racks, metallic conduits and exposed non-current-carrying metal parts of telecommunications and information technology equipment in the MDFs and TRs shall be bonded to the TMGB or TGB. Refer to Chapter 8 *Bonding and Grounding* in the BICSI TDMM and TDDG Section 3.8 *Bonding and Grounding (Earthing)* for more information regarding the design of grounding, bonding, and electrical protection systems.

- Grounding and bonding conductors shall be sized according to the following requirements:
 - NEC Article 250
 - ANSI/TIA/EIA J-STD-607-D.

3.3.11 CABLES ENTERING TELECOMMUNICATIONS ROOMS

All cables shall be fully supported and properly transitioned throughout their lengths, including proper bend radius fittings at pathway transitions.

Where cabling is routed vertically, it shall be appropriately secured such that the weight of the cabling does not subject the cabling to stresses that could potentially reduce the performance of the cabling.

- Provide vertically oriented ladder racking, attached to walls, to carry riser/backbone cabling vertically between telecommunications rooms.

3.3.12 PROHIBITED ITEMS

The following items shall not be located in telecommunications rooms:

- Electrical power transformers
- Electrical power panels, except for the technical power panel serving the telecommunications room
- Lighting control panels
- Access Control Panels (ACP)
- EMI-producing equipment such as HVAC VAV boxes.
- Water piping (except for fire suppression systems)
- Building Automation System (BAS) panels, such as DDC

3.3.13 ENTRANCE FACILITIES

3.3.13.1 OUTSIDE PLANT CONDUIT ENTRANCE

Analog telephone circuits are made available in each building in one of two ways:

- Clemson provides an analog gateway device to derive analog circuits from its VOIP telephone system.
- Utility services are delivered directly to the building by the utility service provider.

Since Clemson does not install or maintain an outside plant copper cabling infrastructure, the entrance facility will require wall space for utility-provided demarc equipment and entrance conduits from the outside plant for utility cabling. Clemson prefers to co-locate the entrance facility within the main telecommunications room (the “MDF”) in a building. The Designer shall inquire about this requirement on each project and shall designate wall space for the utility demarc.

3.3.13.2 ROOFTOP CONDUIT ENTRANCE

Not applicable.

3.3.14 SERVER ROOMS

Normally, all server equipment should be located in the campus data center.

For projects that include server rooms or equipment rooms, the requirements of Section 3.3 *Telecommunications Spaces* apply. (For full-scale Data Centers, see Section 3.18 *Data Centers* below.)

3.4 Backbone Distribution Systems

Please refer to Chapter 4, *Backbone Distribution Systems* in the BICSI TDMM, Chapter 5, *Cabling Infrastructure* and Chapter 6, *Pathways and Spaces* in the BICSI OSPDRM, and Chapter 2, *Pathways and Spaces* in the BICSI ITSIMM for general information regarding the design of backbone distribution pathway and cabling. The following requirements take precedence over the guidelines in those documents for telecommunications infrastructure at Clemson facilities:

3.4.1 INTRA-BUILDING BACKBONE PATHWAYS

- A. Intra-building backbone pathway shall utilize a physical star topology. The Designer, however, shall inquire whether another pathway topology would be appropriate for a given application. Backbone raceway shall consist of conduit, chases or shafts, sleeves, and/or vertically mounted ladder racking.
- B. All cables shall be fully supported and properly transitioned throughout their lengths, including proper bend radius fittings at pathway transitions. Where cabling is routed vertically, it shall be appropriately secured such that the weight of the cabling does not subject the cabling to stresses that could potentially reduce the performance of the cabling.
- C. In new construction and remodel projects:

- The main telecommunications room in the building (MDF) shall have a direct pathway connection to the entrance facility (EF).
- All intermediate telecommunications rooms (IDF/TR) shall have direct pathway connections to the MDF in the building.
 - This is usually accomplished with vertical riser pathway (Specified Technologies Inc. (STI) Ez-Path or another pre-approved equal product).
- For buildings requiring multiple intermediate telecommunications rooms on a given floor, the secondary telecommunications rooms do not require a direct backbone pathway to the main telecommunications room. Instead, the first intermediate telecommunications room on a floor shall have a direct pathway. The other telecommunications rooms shall connect to the first via the main cable tray on that floor.
 - This solution is typically adequate when backbone cables are relatively small compared to the horizontal cable load in the cable tray.
 - Even though **pathway** from one telecommunications room may connect to another telecommunications room before connecting to the main telecommunications room, backbone **cabling** shall not cross-connect in the interposing telecommunications room. Intra-building backbone cabling shall be continuous (non-spliced) between the main telecommunications room and each intermediate telecommunications room.

3.4.1.1 BACKBONE RACEWAY SIZE AND QUANTITY REQUIREMENTS

Future growth requirements shall be considered when sizing intra-building backbone pathways. The cost to install additional spare pathways during initial construction is significantly less than the cost of retrofitting additional pathway in the future.

- In general, for new construction and modernization projects, Clemson requires a minimum of four 4" Ez-Path sleeves leaving the main telecommunications room/entrance facility enroute to the intermediate telecommunications rooms on floors above. However, for buildings higher than five floors, additional Ez-Path sleeves shall be provided.

3.4.1.1.1 SINGLE-STORY BUILDINGS

For single-story buildings with multiple telecommunications rooms, 4" conduit pathways shall be routed through the ceiling, not in or under the floor slab. The Designer shall determine the number of 4" conduits required to serve initial and future backbone cabling requirements.

- In cases where it is not possible to route 4" conduits to each of the telecommunications rooms, three 2" conduits may be substituted for each required 4" conduit.

3.4.1.1.2 MULTI-STORY BUILDINGS

- A. In new construction and modernization projects, telecommunications rooms shall be vertically aligned (stacked) floor-to-floor wherever possible. Sleeved vertical pathways shall be extended to the roof (or to an attic space with access to the roof) to facilitate access for future antennas or other telecommunications equipment. Conduits terminating on a roof shall be capped with a weatherhead.
- B. Ladder racking shall be vertically mounted in the stacked telecommunications rooms to route and support backbone cable passing from the room below to upper rooms.

3.4.2 INTRA-BUILDING BACKBONE CABLING

The diagram below depicts intra-building and inter-building backbone cabling requirements (including strand and pair counts) for Clemson buildings:

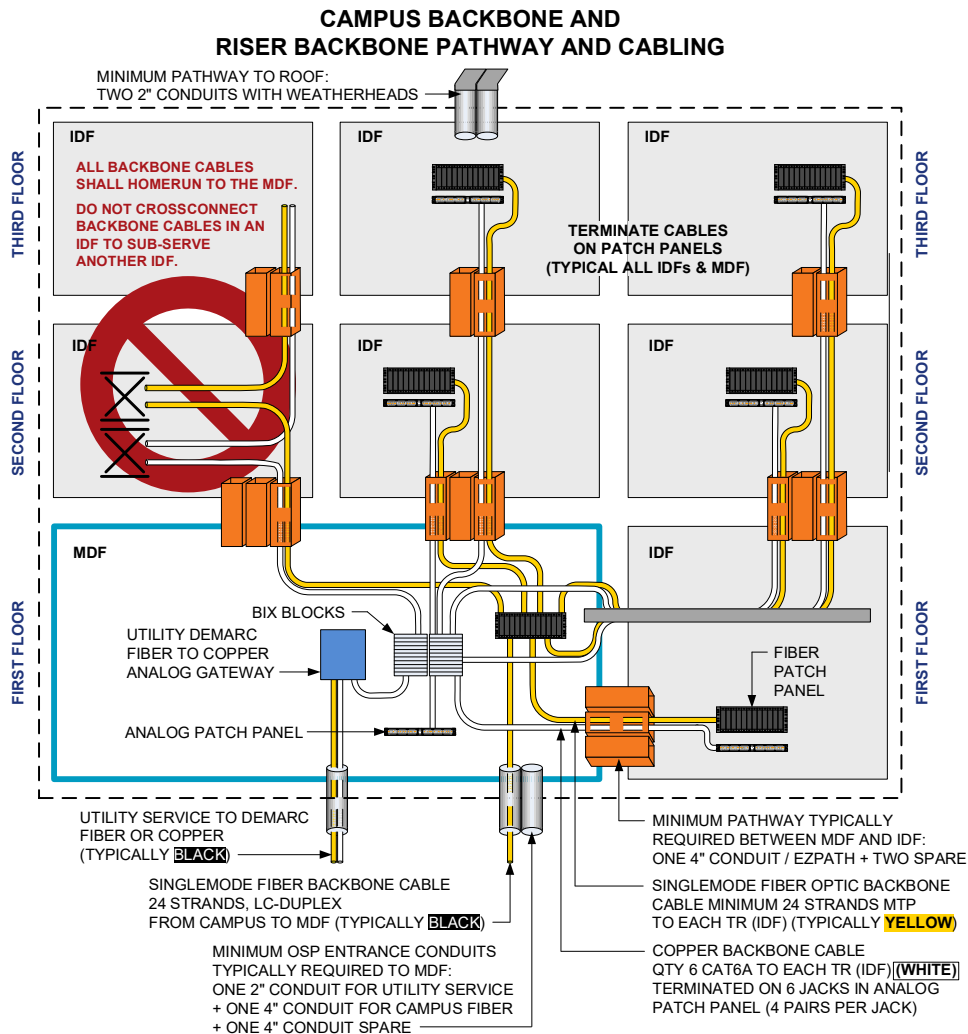

3.4.2.1 INTRA-BUILDING BACKBONE CABLE TYPES

- A. Clemson typically deploys the following types of telecommunications cabling for intra-building backbone systems:
- 8/125µm OS2 singlemode fiber optic cabling, 24 strand (yellow jacket)
 - Quantity of 6 Category 6A copper cables (white jacket)
- B. Splices are prohibited for backbone cabling.
- C. Indoor-rated backbone cabling is acceptable for intra-building backbone applications between physically contiguous buildings.
- D. Indoor/outdoor-rated cabling shall be used where buildings are not physically contiguous.

3.4.2.2 STRAND AND PAIR COUNTS

- A. The diagram in Section 3.4.2 above indicates all standard strand and pair counts.
- B. Backbone cable sizing (# of strands, # of pairs) shall be considered with respect to possible future requirements. The cost to add additional backbone pairs and strands during the initial installation is significantly less than the cost of adding another cable in the future.

The Designer shall inquire with the NSTTL on a case-by-case basis about strand and pair counts for backbone connections between the Campus MC and a Campus IC.

Clemson is considering the use of MTP terminated fiber optic cabling. The Designer shall discuss this option with the NSTTL about its use on a given project.

3.4.2.3 CABLE SEGREGATION

In no case shall copper or fiber optic backbone cabling be run in the same raceways as those used by electrical power conductors. However, copper, fiber optic and other low-voltage cables are permitted to run together in shared raceways.

3.4.2.4 INNERDUCT

Innerduct shall not be used to route fiber optic backbone cabling inside the building.

3.4.3 INTER-BUILDING (CAMPUS) BACKBONE PATHWAYS

The Designer shall follow the guidelines in the BICSI TDMM and the BICSI OSPDRM when designing underground outside plant pathways.

3.4.3.1 DUCTBANK

The diagram below depicts the features of telecommunications ductbank, which are described in detail in the paragraphs that follow.

PREPARE FINISHED GRADE. FOR TURF AREAS, PROVIDE 4" TOPSOIL AND NEW SOD.

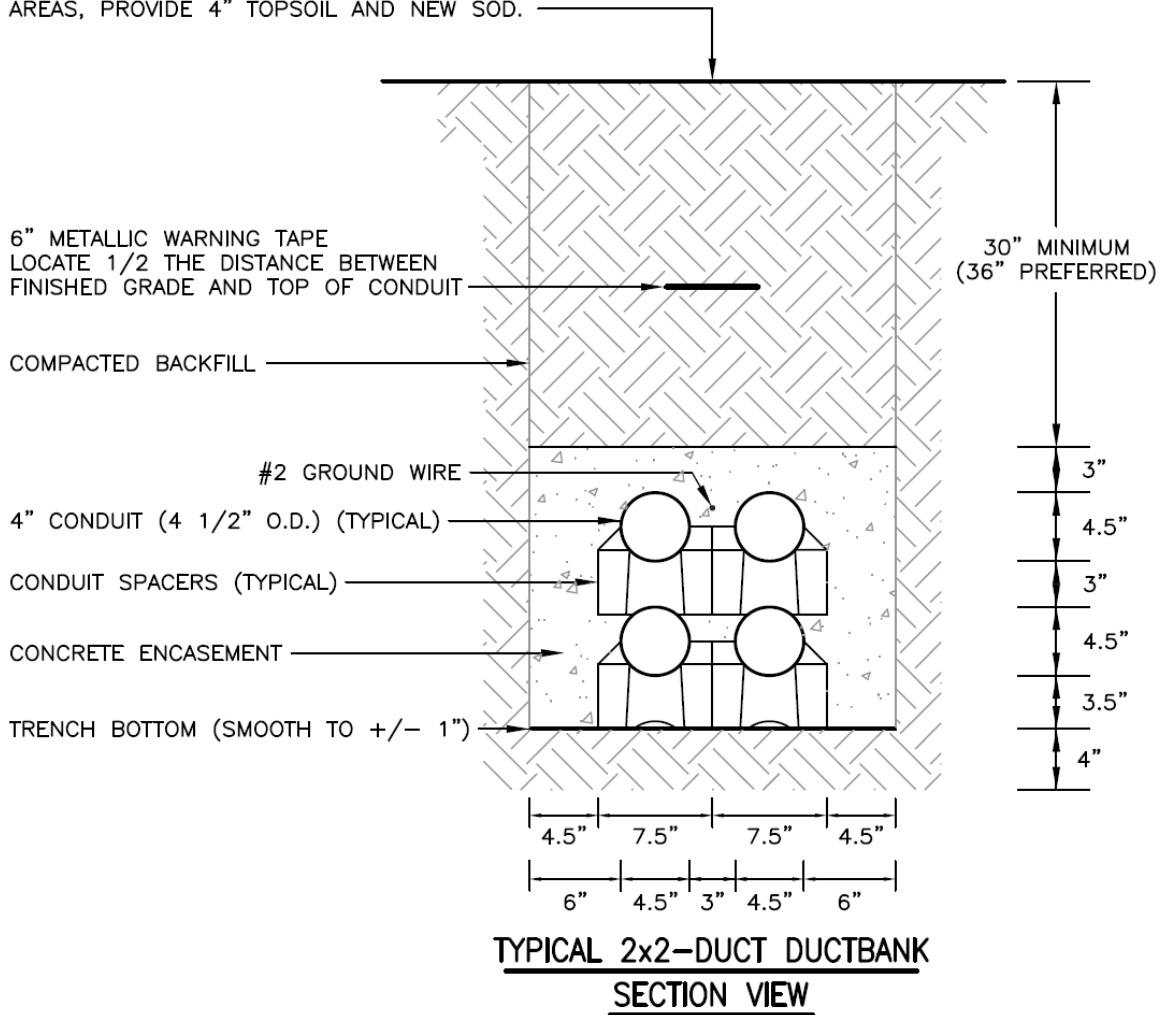

3.4.3.1.1 CONDUIT TYPES

- A. Clemson requires 4" Schedule 40 PVC for all outside plant pathway except ducts serving Blue Light Emergency Telephones, which shall be trade-size 1½ inch conduit.
- B. OSP conduit shall transition from PVC to PVC-coated rigid steel conduit when it enters within 10 feet of the building foundation and shall route from that point to the building entrance facility. PVC-coated, rigid steel conduit is intended to defend against the shearing effects of differential ground settling around the building foundation. It also increases the protection against future landscaping activities near the building.

- Transition back to PVC conduit after passing five feet inside the building foundation is acceptable as long as the conduit remains in or under the slab; otherwise it shall transition to rigid galvanized steel conduit.
- Rigid galvanized steel conduit shall be used to route incoming backbone cable until it is close enough to its termination point that fifty feet or less of outdoor-rated cable (including slack loops) will be exposed. While Clemson requires indoor/outdoor fiber optic cabling, utility service copper cabling is normally outdoor rated.

C. The use of flexible metallic conduit is prohibited.

3.4.3.1.2 GROUND CONDUCTOR

- A. A continuous ground conductor (#2 AWG) shall be installed running the length of each ductbank. The ground conductor shall be placed on the top row of conduits so that it will be detectable by underground utility locating equipment.
- B. The ground conductor shall be bonded to other ground conductors from other ductbanks meeting at an underground maintenance hole or handhole.
- C. The ground conductor shall be bonded to the main telecommunications grounding busbar in the MDF or main entrance facility of the building.

3.4.3.1.3 BURIAL DEPTH AND SLOPE

- A. The preferred ductbank depth is 36" to the top of the conduit. Where this is unattainable, a 30" depth is permitted.
 - In the Clemson, SC area, there is no defined frost zone. However, the Designer shall be cognizant of the risk of conduits rising to the surface in certain soil types, and design appropriate concrete encasement and burial depth to prevent conduit floating.
- B. A continuous drain slope should exist at all points along the ductbank to allow drainage and prevent the accumulation of water.
 - A drain slope of ¼" per foot is desirable where possible.
 - Where ¼" per foot is not possible due to inadequate natural slope or long duct runs, a drain slope of no less than 1/8" per foot is acceptable.
 - If no other option exists, the Designer shall require the Contractor to provide a "center crown" drain slope by sloping the first half of the ductbank up toward the midpoint, and then down from the midpoint to the end. Of course, the center crown technique cannot be used for conduits between a maintenance hole and a building, because water would then drain into the building.

3.4.3.1.4 CONDUIT SWEEPS (BENDS)

- A. Clemson has standardized on the use of factory-manufactured fiberglass sweeps with a minimum bend radius of 48" for all OSP ductbanks with the following exceptions and alternatives:

- Shallow curves consisting of continuous lengths of individual straight RNC conduit are permissible with a minimum sweep radius of 40 feet.

3.4.3.1.5 DUCTBANK ENCASUREMENT

Clemson requires concrete encasement with full-length reinforcement and formed sides for all ductbanks.

- A. Prior to concrete being poured, the NSTTL or a designated representative shall observe the OSP conduit installation to identify unacceptable installations that need to be corrected prior to concrete encasement.
- B. Should the use of direct-buried conduit ductbank be warranted, the Designer shall ensure that all bends in the ductbanks are encased.
- C. Wherever cold-joints are required in concrete encasement, the design shall require rebar spanning the joint between ductbank encasement segments to avoid differential settling.

3.4.3.1.6 NUMBER OF DUCTS

- A. The OSP pathway system shall accommodate the requirements for signal and low-voltage cabling systems at Clemson facilities. The Designer shall inquire with the NSTTL and FPM about the potential for future buildings or building expansions that may adversely affect an existing or proposed distribution pathway, and accommodate those plans within the design.
- B. The number of 4" conduits in a ductbank should meet the needs of the specific application and should offer future expansion capability. The following list is a guideline for consideration when designing a new ductbank.
 - Small utility buildings up to 5,000 sq. ft.: 2 ducts (approvable on a case-by-case basis)
 - Buildings up to 150,000 sq. ft.: 3 ducts
 - Buildings 150,000 sq. ft. to 300,000 sq. ft.: 4 ducts
 - Buildings larger than 300,000 sq. ft.: multiple redundant entrances with 4 ducts each
 - Buildings serving as data centers or communications centers: multiple redundant entrances with 8 ducts each

3.4.3.1.7 DUCTBANK LENGTH

- A. In general, ductbank systems shall be designed with section lengths averaging 400 feet, and as straight as possible.
- B. The maximum permissible ductbank length (between maintenance holes and/or buildings) is 500 ft. Ductbank runs that exceed this distance require intermediate maintenance holes or handholes. This requirement may be waived through the SVR process in rare cases having the following conditions:
 - The ductbank run has no bends.

- The Designer can demonstrate that the pulling tension of Clemson’s standard OSP telecommunications cable types will not be exceeded during installation.

3.4.3.1.8 SEPARATION FROM OTHER UTILITIES

- A. In general, ductbank used as pathway for telecommunications and other low-voltage cabling should not be routed with other utilities. Budgetary constraints, space limitations, and various obstructions can make this difficult to achieve at times. Should shared routing be a necessity (perhaps for overbuild construction projects), the Designer shall ensure that adequate separation exists between ducts used for telecommunications and ducts used for other utilities.
- B. The pathway system shall be designed such that telecommunications and other low-voltage systems do not share conduits, maintenance holes, handholes, or tunnels with the electrical power distribution system. The telecommunications distribution pathway shall also maintain minimum separation distances from electrical power distribution infrastructure as required by Clemson.
- C. There are cases at Clemson where OSP telecommunications cabling routes through existing utility tunnels that are shared with power and steam. This is a suboptimal situation that should not be perpetuated for new projects wherever possible. The Designer shall discuss this topic with the FPM and NSTTL if a project appears to include tunnel routing.

The vertical and horizontal separation requirements for OSP telecommunications pathways from other underground utility infrastructure are as follows:

3.4.3.1.8.1 Proximity to Power or Other Foreign Conduits

The requirements in NESC 320B state that outside plant telecommunications conduits shall not be installed closer to power conduits or other unidentified underground conduits than:

- 3” where the surrounding material is concrete
- 4” where the surrounding material is masonry
- 12” where the surrounding material is well-tamped earth

While the NESC requirements above are focused on safety and maintenance issues, the performance of telecommunications systems can be negatively affected by the presence of nearby sources of EMI, even though the NESC safety-related separation requirements are met. Where the Designer is concerned about EMI due to the proximity of power distribution infrastructure, the Designer shall discuss the issue with the NSTTL.

3.4.3.1.8.2 Proximity to Water, Gas, or Oil Conduits

Outside plant telecommunications conduits shall not be installed closer than 6” or 12” to conduits that can be identified as not containing electrical power distribution conductors, as follows:

- 6” where the conduits cross
- 12” where the conduits run parallel to each other

Telecommunications conduits running parallel to water, gas, or oil conduits shall not be installed vertically above the other conduits, but rather to the side of the conduits. This arrangement should contribute to decreased disruption to the telecommunications conduits in the event of excavation maintenance activities associated with the other nearby conduits.

3.4.3.1.8.3 Proximity to Steam Lines and Steam Utilidors

- A. A minimum separation distance of 12 inches is required between a steam utilidor and telecommunications conduits.
- B. Steam lines pose two primary risks to telecommunications cabling:
 - Under steady state operating conditions, objects in the vicinity of steam lines may become warm due to heat lost through the insulation of the steam line. As the temperature of telecommunications cabling increases, its performance can degrade. In situations where there is concern about the risk of exposure to steady state heat, the separation distance between the steam line and telecommunications infrastructure shall be increased.
 - In the event of a steam line failure in the proximity of telecommunications infrastructure, significant damage to the conduits and cabling can result from the high-temperature steam. In situations where there is concern about the risk of exposure to high temperatures from steam line failure events, the design shall require telecommunications conduits to be encased within an insulating sleeve in the vicinity of the risk.
- C. High-temperature insulation may be necessary to protect telecommunications conduits and cabling.
- D. Clemson's practice is to install steam lines in utilidors, rather than to direct-bury the steam lines. The utilidors are typically 3 to 4 feet high, and may be buried with 0 to 2 feet of surface cover. Therefore, the bottom of most utilidors on campus is typically somewhere between 3 and 6 feet deep.
- E. The Designer shall field-investigate the actual utilidor routing to identify accurate field conditions. Potholing to confirm record drawing information is typically required.
- F. Where physical conditions appear to preclude compliance with the following requirements, an SVR shall be submitted demonstrating solutions for mitigating exposure to worst-case conditions, including steam line failure where steam vents in the direction of the telecommunications conduits.

3.4.3.1.8.3.1 Crossing Steam Utilidors

The Designer shall consult with a civil engineer whenever crossing above or below a steam utilidor. Maintain at least 12 inches of clearance between the utilidor and the telecommunications conduits, and avoid dips in the conduits where water will collect.

3.4.3.1.8.3.2 Direct Buried Steam Lines

If it becomes necessary to install telecommunications conduits in the vicinity of direct-buried steam lines, the following requirements apply:

- Telecommunications conduits shall not be installed closer than 12 inches to steam lines, and shall cross perpendicular to the steam lines.
- Direct-buried steam lines within 12 to 24 inches of telecommunications conduits shall be encased within an insulated pipe sleeve surrounding the steam line. The sleeve shall be constructed from a material designed to withstand steam temperatures and protect against physical/mechanical damage from jets of steam. The insulated sleeve shall extend at least 5 feet on both sides of the crossing point of the telecommunications conduits.

3.4.3.1.9 INNERDUCT

It is Clemson's preference to use innerduct to protect fiber optic backbone cabling.

Both 1" and 1¼" innerduct can be used as appropriate for the application. When designing cabling runs through outside plant conduit:

- Design fiber optic cabling runs using innerduct.
- Fill the remaining space in a used conduit with empty innerduct.
- Do not fill vacant conduits with innerduct.

3.4.3.1.10 COORDINATION WITH UTILITY SERVICE PROVIDERS

The Designer shall inquire with the NSTTL to determine whether services from utility service providers will be necessary. If so, the Designer shall contact the utilities to obtain their entrance pathway, entrance facility, and demarcation point requirements.

3.4.3.2 MAINTENANCE HOLES AND HANDHOLES

- A. Clemson prefers to use pre-cast maintenance hole products that are 6 ft wide by 8 ft long by 7 ft high and handholes that are 4 ft x 4 ft x 4 ft.
 - The Designer shall be responsible to select an appropriate maintenance hole or handhole for each application, especially taking into consideration the potential traffic load that may contact the vault.
- B. Typically, maintenance holes are installed for main ductbanks (i.e. ductbanks used for routing large portions of the telecommunications system backbone), and handholes/pullholes are installed for subsidiary ductbanks (i.e. ductbanks serving a single small building).
- C. Maintenance holes and their covers shall be appropriately sized for the application.
 - Diamond plate hinged covers are not permitted for maintenance holes at Clemson.

- D. Telecommunications maintenance holes and handholes shall not be shared with electrical power distribution infrastructure. In general, powered devices should not be located in telecommunications maintenance holes and handholes.
- E. The number of duct entrances in a maintenance hole or handhole should be sized for both immediate and future requirements. Also, splayed duct entrance arrangements are preferred over center entrances.
- It is desirable to have ducts enter and exit from opposite ends of a maintenance hole or handhole. Sidewall duct entrances should be avoided because such entrances may obstruct racking space, cause cable bends to exceed limits, interfere with cable maintenance activities, and increase construction costs during cable installation.
 - Clemson recognizes that sidewall duct entry may be necessary or desirable in some circumstances. In these cases, sidewall ducts shall enter and exit at diagonally opposite corners – ducts shall not enter and exit at the midpoints of the endwalls or sidewalls. The Designer shall ensure that endwall and sidewall duct entry in a maintenance hole or handhole will not hinder access to the maintenance hole or the proper installation and maintenance of cabling.
- F. Ducts shall be designed to enter the maintenance holes and handholes starting at the lowest conduit knockouts and moving upward, preserving remaining knockouts accessible for future conduit additions. The Designer shall design the duct entrances such that the relative position of each duct does not change as it enters and exits the maintenance hole or handhole. Also, the Designer shall endeavor to design ductbank arrangements so that the conduits enter and exit a sequence of maintenance holes or handholes in the same relative positions.
- G. Splices in backbone fiber optic cable are not allowed. However, when sizing OSP telecommunications maintenance holes, the design shall require the Contractor to provide space for possible future splice closures when required (for example, to repair cable breaks).
- H. Some situations may require placement of maintenance holes at below-typical depths. In such cases, the top of the maintenance hole shall be placed at normal depth and the height of maintenance hole shall be increased through the use of intermediate riser extensions between the base and the top. Clemson wishes to avoid deep-collar entrance portals wherever possible, to improve lighting and ventilation.

3.4.3.3 AERIAL DISTRIBUTION

Aerial distribution of telecommunications cabling at Clemson facilities is not authorized. If an application requires aerial distribution, permission to use this method shall be requested through the SVR process.

3.4.3.4 BRIDGE AND WATERWAY CROSSINGS

A civil engineer shall review the construction of bridge and waterway crossing distribution systems. The design and installation shall also be reviewed by the NSTTL.

3.4.3.5 WIRELESS AND RADIO SYSTEM DISTRIBUTION

Clemson facilities frequently use rooftop satellite, wireless or radio systems. These systems typically use one or more radio antennas connected by cabling to radio transceiver equipment. Pathways shall be designed from rooftop locations down to the main telecommunications room to serve these applications.

3.4.4 CAMPUS CABLING

When OSP cabling is required, the Designer shall follow the guidelines in the BICSI TDMM and the BICSI OSPDRM.

- A. The design shall require that a slack loop be installed inside the nearest maintenance hole or handhole (not stored in the TR). The Designer shall require that sufficient racking hardware be provided in the maintenance hole or handhole to support the slack loop.
- B. The length of the loop shall be a minimum of 25 feet. The Designer shall consider the arrangement of the telecommunications room and the possibility of a rearrangement that might consume the cable slack. If necessary, additional slack shall be required in the design, up to the NEC limit of 50 feet of exposed OSP-rated cabling.

3.4.4.1 CABLING TYPE

Clemson installs only singlemode fiber optic cabling for its outside plant cabling infrastructure, and is considering the use of MTP terminations. The Designer shall discuss this option with the NSTTL about its use on a given project. See Section 3.4.2 *Intra-building Backbone Cabling* above for additional information.

3.4.4.2 UTILITY SERVICES

At Clemson, VOIP telephone services and Internet services are typically provided via campus infrastructure.

Analog telephone utility services provided by AT&T require a dedicated 4" conduit routed with the University's ductbank and entrance conduits.

The Designer shall inquire with the NSTTL about whether any other utility services (perhaps cable television) will need a dedicated conduit.

3.4.4.2.1 NON-CLEMSON TENANT DEMARC

Providing telephone and Internet services for non-Clemson tenants will be evaluated on a case-by-case basis. One option is for the tenant to obtain services from a utility service provider.

A second option is for Clemson to provide the services to the tenant. In this case, Clemson telecommunications infrastructure shall not be accessible from tenant demarc facilities which may be located inside the tenant's space.

The Designer shall inquire with the NSTTL about how services should be provided to non-Clemson tenants and whether any telecommunications infrastructure should be included in the scope of a project.

3.4.4.3 WIRELESS AND RADIO SYSTEM DISTRIBUTION

- A. Outdoor-rated backbone cabling shall be designed to serve rooftop satellite, wireless or other radio system applications. Lightning protection equipment shall also be designed as appropriate.
- B. Radio antenna transmission cables that connect the antenna to the radio transceiver emit radio frequency (RF) radiation. These cables may be routed in a separate conduit from other telecommunications cables. Cables carrying signals that produce RF radiation shall be shielded cables.

3.5 Horizontal Distribution Systems

Please refer to Chapter 5, *Horizontal Distribution Systems* in the BICSI TDMM for general information regarding the design of horizontal distribution pathway and cabling. The following requirements take precedence over the BICSI TDMM guidelines for telecommunications infrastructure at Clemson facilities:

3.5.1 DEVICE BOX CONSIDERATIONS

- A. Device boxes for telecommunications outlets shall be mounted at standard outlet mounting height, matching electrical power outlets. Typically this is 18" above finished floor.
- B. Device boxes shall include double gang reducing rings that support a single gang faceplate. Surface raceway applications and wall-mounted telephone applications may require single gang faceplates.
- C. 5" square x 2.875" deep device boxes are required for Category 6A cabling.
 - There are three known sources of 5"x 5" device boxes:
 - RANDL Industries, Inc. (www.randl-inc.com)
 - Siemon (www.siemon.com)
 - Thomas & Betts (T&B) (www.tnb.com)

- D. The provision of spare outlets and spare ports in a work area is encouraged to provide flexibility for future needs.
- E. Clemson intends to never install coaxial cabling for television in any campus facilities, including residential facilities.
- F. Device boxes intended for use with low-voltage cabling (telecommunications, CATV, etc.) shall not host electrical power receptacles or power wiring. “Combo boxes” (divided, multi-gang device boxes for power and data behind a single faceplate) are not permitted.

3.5.1.1 FLOOR BOXES

- A. Device boxes shall not be mounted in the floor (i.e. “floor boxes”) except where no suitable alternative exists. If device boxes must be mounted in the floor, each device box shall be served with its own individual conduit – floor boxes shall not be “daisy-chained” together.
- B. Power outlets may be combined with telecommunications cabling in floor boxes if the power wiring is routed to the floor boxes separately from the telecommunications cabling, and if the floor box provides for metallic barrier segregation of the power and telecommunications cabling within the box.
- C. In many cases, floor boxes will be intended to host audio/visual cabling in addition to telecommunications and power. In such cases, coordinate with the audio/visual designer and the AVTL to achieve both telecommunications and audio/visual objectives.
- D. Floor boxes shall be one of the following options depending on size requirements, cable handling requirements, and construction circumstances:
 - Floor box: FSR FL-500P-x series with associated accessories
 - Floor box: FSR FL-600P-x series with associated accessories
 - Floor box: Hubbell CFB7Gx series with associated accessories
 - Poke-thru: Legrand Evolution xATC series with associated accessories

The Designer shall review with the NSTTL the selection of floor box type or poke-thru for each application.

3.5.1.2 FOR NEW CONSTRUCTION AND FULL REMODEL

- A. A device box shall be provided for each telecommunications outlet. Device boxes shall be 5” square x 2.875” deep. Device boxes shall be recess-mounted.
- B. Surface-mounted device boxes are not acceptable. However, for concrete masonry unit (CMU) walls or other wall types that may obstruct cable or conduit installation, the Designer shall request direction from the NSTTL on a case-by-case basis.



3.5.1.3 FOR OTHER PROJECTS

- A. Existing device boxes and conduits shall be reused where they are standards-compliant, or where it can be verified that the existing conduits and boxes will permit telecommunications cabling to be installed without negatively affecting the performance of the cabling. The bend radius of the cabling inside each box shall be considered carefully in evaluating existing boxes. For concealed conduits that cannot be verified, the Designer shall assist the NSTTL to consider conduit length, number of bends, and cable fill percentage, then decide on a case-by-case basis whether they are suitable for reuse.
- B. A device box shall be provided for each telecommunications outlet. Device boxes shall be recess-mounted wherever possible and shall be 5" square x 2.875" deep. Surface-mounted device boxes (if required) may be standard single gang (2" x 4") and at least 2½" deep.
- C. Where cabling can be fished through interstitial wall spaces, it is typically permissible to use faceplate mounting brackets in lieu of device boxes.

3.5.2 WORK AREAS

3.5.2.1 STANDARD TELECOMMUNICATIONS OUTLETS

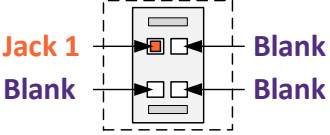
- A. Clemson's "standard telecommunications outlet" shall have 1 cable, 1 jack and 3 blanks mounted in a single gang faceplate with 4 holes (not Decora style). The Designer shall coordinate with the interior designer to match faceplate color and material (plastic versus stainless steel) with other utilities and features.
 - Each jack shall terminate a separate cable. Do not under any circumstances split pairs on data jacks.
- B. Many applications in a project will require different numbers of cables in an outlet. See the diagram below depicting the faceplate, jack, and blank arrangements for each application:

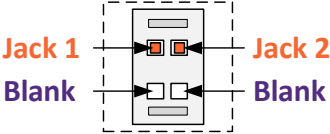
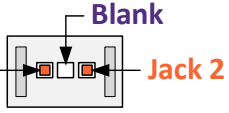
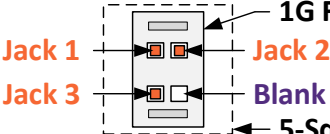
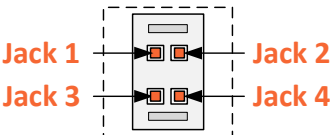
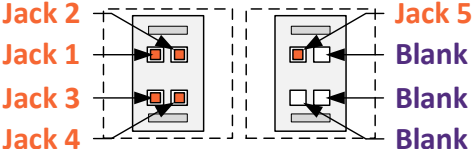
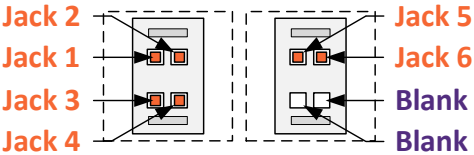
Outlets with 1 Cable	 Jack 1 Blank Blank Blank  Wall-mounted Telephone Outlet Jack 1 No Studs
Outlets with 2 Cables	 Jack 1 Blank Jack 2 Blank  Surface Raceway Maximum 2 Jack 1 Cables per Outlet Blank Jack 2
Outlets with 3 Cables	 Jack 1 Jack 3 Jack 2 Blank 1G Faceplate (Typical) 5-Sq Box (Typical)
Outlets with 4 Cables	 Jack 1 Jack 3 Jack 2 Jack 4
Locations with 5 Cables	 Jack 2 Jack 1 Jack 3 Jack 4 Jack 5 Blank Blank Blank
Locations with 6 Cables	 Jack 2 Jack 1 Jack 3 Jack 4 Jack 5 Jack 6 Blank Blank

3.5.2.2 PERMANENT OFFICE SPACES

There are two sizes of permanent office spaces depicted below, with outlet locations identified for each case:

3.5.2.2.1 STANDARD OFFICES (UP TO 120 SQUARE FEET)

- A. Provide one outlet with one cable on the interior wall in the corner opposite the door, as shown in the floor plan at right.

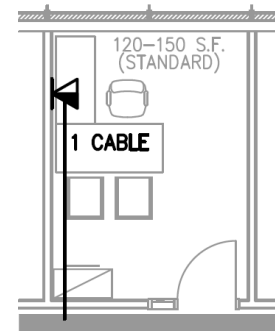

3.5.2.2.2 LARGE OFFICES (120 TO 150 SQUARE FEET)

- A. For larger offices, provide two outlets with one cable each on opposite sides of the room. The outlets shall be arranged as shown in the floor plan below, intended to complement the possible furniture orientations and maximize patch cord coverage in the room shown in the floor plan below.
- B. If an exterior wall will not support an outlet due to windows or structural obstructions, it is acceptable to place two outlets on a single wall if they are spread apart and one of the outlets is near the exterior wall.

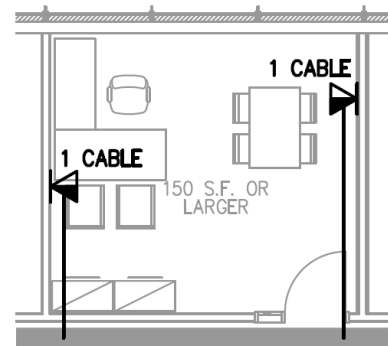

3.5.2.3 OPEN OFFICE/MODULAR FURNITURE

- A. Clemson prefers to serve open office areas using permanently mounted outlets in the wall nearest the modular furniture. Where modular furniture is not located adjacent to a wall, floor boxes are required.
- It is usually preferable to route cabling inside concealed conduits or through interstitial wall spaces. Therefore, columns that are wrapped or furred are preferable because conduits and device boxes can be concealed inside.
 - The NSTTL may authorize the use of surface-mounted raceway in certain projects for columns that are not able to conceal raceway.
 - Where columns and floor boxes do not exist and cannot be added, utility poles shall be designed as a last resort.
 - Where columns are available, raceways shall route cabling down from the ceiling space to two outlets on opposite sides of each column, allowing furniture to sit against the columns on the sides without outlets.
 - Outlets on columns shall have up to 6 ports per outlet.
- B. Raceways integrated into modular furniture shall have separate channels for power and data. The channels shall be designed with abrasion protection

features.

- C. The standard treatment for each modular furniture office space (cubicle) is one data jack with one Category 6A cable.

The following diagram depicts Clemson's preferred method of routing cabling to modular furniture:

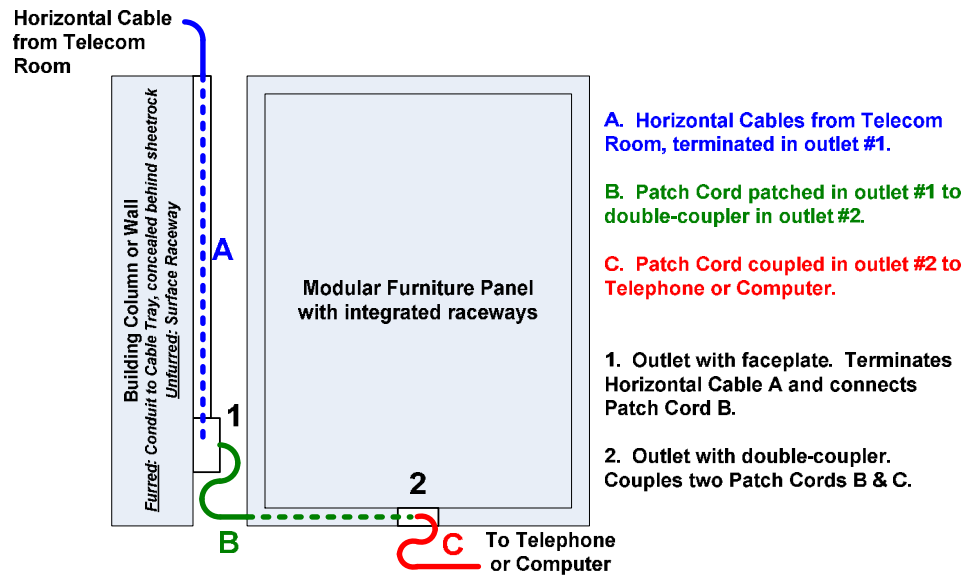

The diagram below depicts an alternative method of routing cabling to modular furniture for use if the preferred method (above) is not practical.

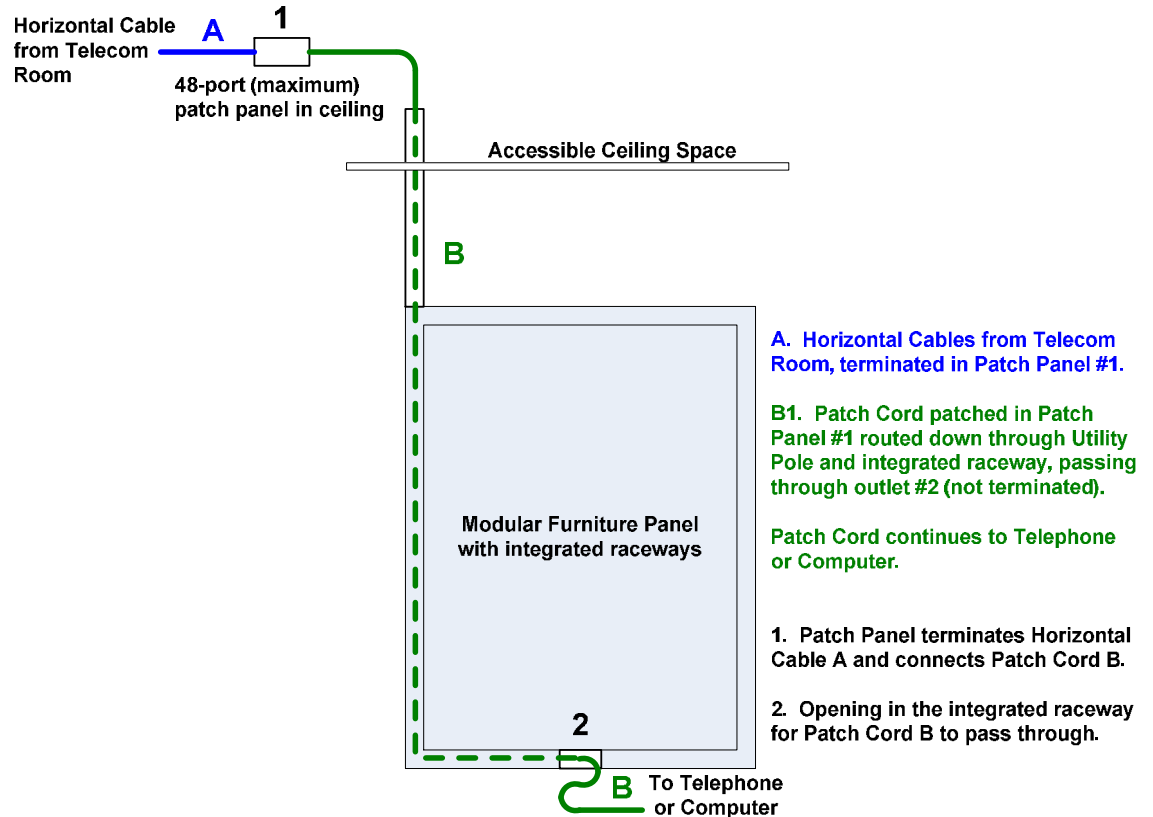

- D. Furniture shall not obstruct access to power or telecommunications outlets. Where necessary, access panels shall be provided and/or holes shall be cut through obstructions to allow access to the outlets.

3.5.2.4 TELECOMMUNICATIONS OUTLETS FOR WIRELESS ACCESS POINTS

- A. Clemson currently uses Cisco wireless access point equipment in its buildings. This equipment operates with Power-over-Ethernet (POE) and requires one Category 6A cable per device. The Designer shall accommodate POE equipment in the design, including the power and cooling requirements.
- B. The Designer shall work cooperatively with the NSTTL to design telecommunications infrastructure to appropriately support wireless technologies. The Designer shall work with the NSTTL to identify the locations where wireless access points (WAP) are desired, and the Designer shall show these locations and corresponding infrastructure on the drawings. On occasion, Clemson may request services to identify appropriate WAP locations and prepare associated coverage and signal strength maps.

3.5.2.4.1 STANDARD PROVISIONS

- A. The Designer shall provide a set of floor plan drawings to the NSTTL, who will then coordinate within CCIT NST to assign a Clemson wireless network engineer to identify locations for wireless access points. CCIT NST will provide a marked-up set of drawings indicating these locations. The Designer shall add the appropriate quantity of outlets and jacks to support each of the locations designated by CCIT NST.
- B. Outlets serving wireless access points shall be mounted above a T-bar ceiling. Where there is no T-bar ceiling, outlets shall be installed between a range of 10' and 12' above finished floor, preferably in the low end of that range. Outlets shall be attached to structure or walls. Do not mount outlets for WAPs above inaccessible ceilings.
- C. Outlets serving wireless access points shall be mounted near where WAPs will be deployed.
- D. Each standard outlet shall have one Category 6A cable.
 - Outlets serving WAP applications may also serve other ceiling-mounted applications such as IP video surveillance cameras. If so, additional cables can be provided for those purposes. See Section 3.5.2.5 for information about video surveillance applications.
- E. Typically Clemson furnishes WAP equipment to the Contractor who installs the WAPs and patch cords throughout the building. This scope shall be included in the drawings and specifications for a project. The Designer shall discuss this with the NSTTL to verify that WAP installation is desired.
- F. The following diagram depicts Clemson's preferred method of installing conduits, boxes, outlets and the wireless access point equipment for most applications:

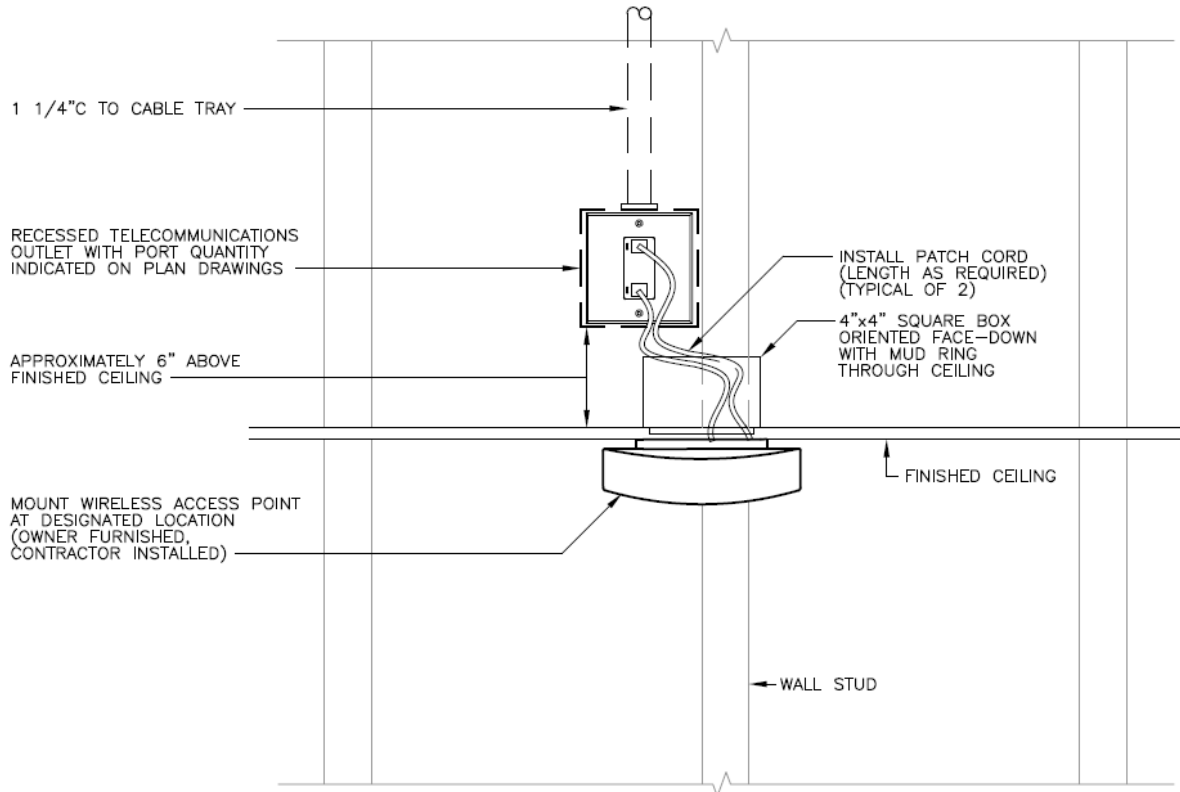

3.5.2.4.2 AREAS OF HIGHER WAP CONCENTRATION

The following WAP outlets shall be provided in addition to the standard provision coverage WAPs described above.

Classrooms and Lecture Halls	Outlets and Cables
25 seats or less	<ul style="list-style-type: none"> One outlet with one data cables in the center of the ceiling.
26 to 50 seats	<ul style="list-style-type: none"> Two outlets with one data cable each, located in opposite corners in the ceiling.
51 or more	<ul style="list-style-type: none"> Preferred: For every 250 square foot space, one outlet in the ceiling with one data cable and a WAP with a directional antenna. OR Consider: For every 250 square foot space, one floor box 14"x14"x4" with two data cables (see floor box detail below).
	<ul style="list-style-type: none"> For every 900 square foot space, one outlet with one data cable in the ceiling.

WAP Locations for Auditoriums with more than 50 Seats

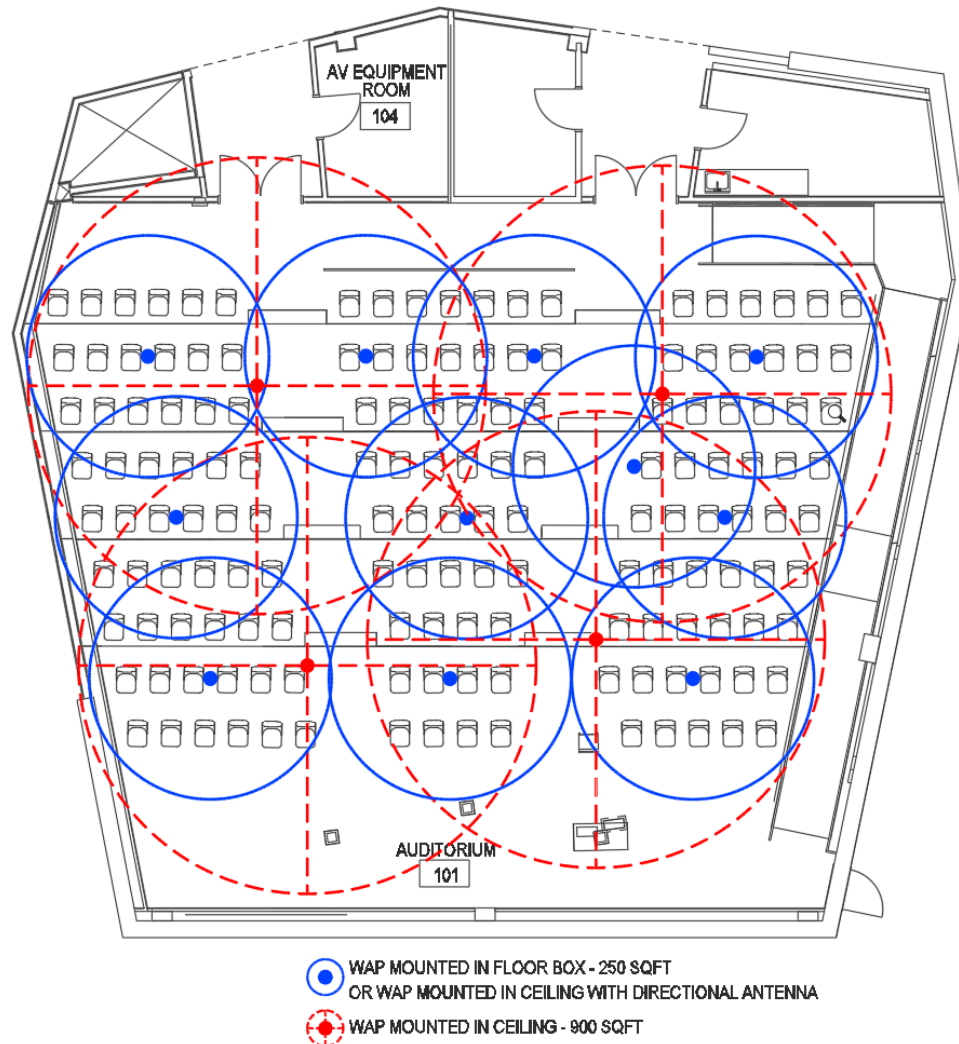

Floor boxes for in-floor WAPs shall be addressed in two varieties:

3.5.2.4.2.1 Fixed-seating Applications

Fixed-seating applications are rooms where the chairs and tables are permanently affixed (not movable).

In order for the wireless signal to pass through the cover of a floor box, the cover must be non-metallic. Floor boxes shall therefore be placed directly below seating, between the legs supporting a seat. This location is intended to protect the cover of the floor box from the risk of weight-load damage.

All floor boxes supporting WAP applications shall have the following features:

- A low profile surface-mounted outlet box
- Two data cables

The Designer shall inquire with the NSTTL and the AVTL to determine whether one or two of the floor boxes in a room supporting WAP applications shall have the following additional features intended to support live video broadcast:

- A low profile surface-mounted outlet box for a power outlet
- A third data cable

The detail on the following page depicts how floor boxes supporting WAP applications shall be constructed in fixed-seating spaces.

3.5.2.4.2.2 Flexible-seating Applications

Flexible-seating applications are rooms where the chairs and tables are movable. They can therefore not be expected to protect the plastic floor box covers described above in fixed-seating applications. In fact, a chair leg positioned on a plastic cover might break through.

Clemson has not yet selected a floor box material, manufacturer, or solution for flexible-seating applications. The Designer shall work with the NSTTL and the project architect to design an acceptable solution following the fixed-seating application described above.

WiFi floor box solution for fixed seating applications.

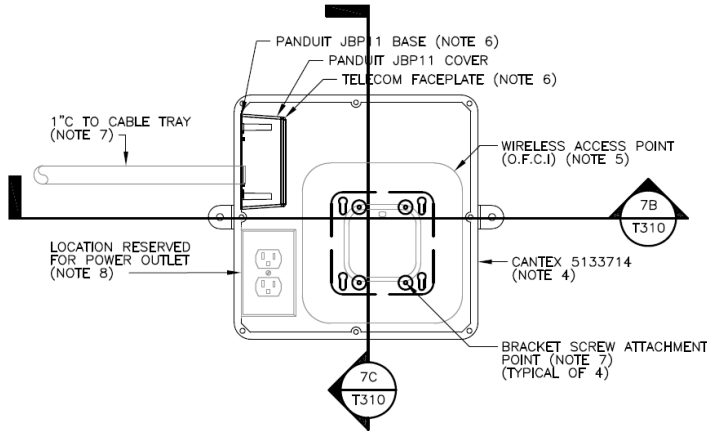

DETAIL 7A/T310
FLOOR BOX FOR WIRELESS ACCESS POINT
TOP VIEW
 SCALE: 2"=1'-0"

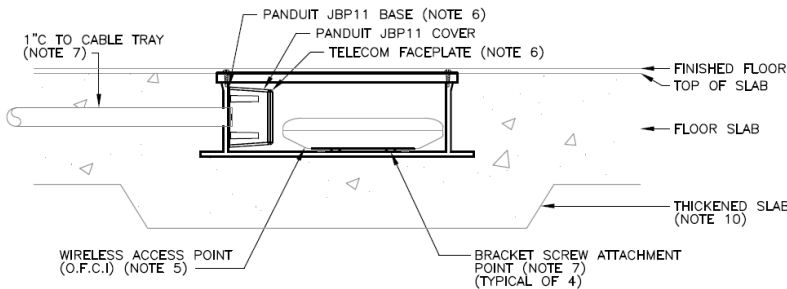

DETAIL 7B/T310
FLOOR BOX FOR WIRELESS ACCESS POINT
SIDE VIEW (CONDUIT)
 SCALE: 2"=1'-0"

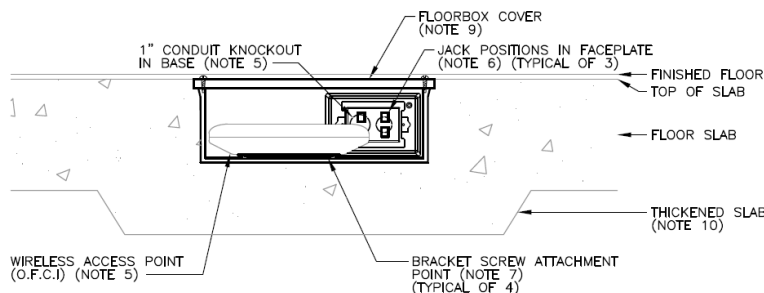

DETAIL 7C/T310
FLOOR BOX FOR WIRELESS ACCESS POINT
SIDE VIEW (FACEPLATE)

NOTES:

1. PROVIDE CANTEX 5133714 FLOOR BOX AND TWO COVERS (NO EXCEPTIONS).
2. INSTALL OWNER-FURNISHED WIRELESS ACCESS POINT AND MOUNTING BRACKET. PROVIDE NETWORK PATCH CORDS.
3. PROVIDE PANDUIT JBP11 BOX WITH AN OVERALL HEIGHT OF 2.27 INCHES (THIS DIMENSION IS ESSENTIAL TO THE DESIGN). REMOVE 3/4" KNOCKOUT AND ORIENT BASE AS DESCRIBED IN NOTE 5 BELOW. ATTACH BASE OF BOX TO INSIDE OF FLOOR BOX WALL, CENTERED VERTICALLY AND SECURE WITH CONDUIT LOCKNUT AND PER MANUFACTURER REQUIREMENTS.
4. PROVIDE 3/4" CONDUIT THROUGH FLOOR TO WALL, THEN UP WALL AND TO CABLE TRAY IN CORRIDOR. MINIMIZE CONDUIT BENDS AS SPECIFIED. DO NOT DAISY-CHAIN MULTIPLE FLOOR BOXES. EACH FLOOR BOX SHALL BE SERVED WITH A DEDICATED CONDUIT. CUT HOLE FOR CONDUIT THROUGH SIDEWALL OF FLOOR BOX. SEE NOTE 5.
5. ORIENT BASE (AND CONDUIT PENETRATION) AS SHOWN, WITH THE 3/4" KNOCKOUT CLOSER TO THE CENTER OF THE SIDEWALL. THIS ORIENTATION IS ESSENTIAL TO THE DESIGN OF THE APPLICATION TO ALLOW SPACE FOR CABLE TERMINATIONS.
6. PROVIDE TELECOMMUNICATIONS FACEPLATE WITH 4 JACK SPACES. FOR APPLICATIONS DESIGNATED WITH 3 CABLES AND JACKS, USE THE JACK SPACES IN THE FACEPLATE AS SHOWN SO THAT THE PATCH CORDS DON'T COLLIDE WITH THE WIRELESS ACCESS POINT. PROVIDE BLANK INSERTS FOR UNUSED SPACES.
7. ATTACH BRACKET (OWNER-FURNISHED) TO BOTTOM OF BOX PER BRACKET MANUFACTURER'S RECOMMENDATIONS. ENSURE THAT THE BRACKET POSITION WILL ALLOW WIRELESS ACCESS POINT TO FULLY SLIDE INTO SLOTS FOR MOUNTING PEGS. BRACKETS SHALL BE POSITIONED TO HOLD THE WIRELESS ACCESS POINT CLOSE TO THE TWO SIDEWALLS AS SHOWN WITHOUT MAKING CONTACT.
8. SOME FLOOR BOX APPLICATIONS MAY ALSO REQUIRE A POWER OUTLET. IF SO, THE POWER OUTLET SHALL BE MOUNTED FACE UP AS SHOWN IN THE LOCATION INDICATED. A CONDUIT FOR THE POWER CIRCUIT SHALL BE TERMINATED THROUGH THE SIDE WALL NEAR THE POWER OUTLET. THIS ARRANGEMENT IS ESSENTIAL TO THE DESIGN OF THE APPLICATION. NO EXCEPTIONS TO THESE REQUIREMENTS SHALL BE PERMITTED.
9. POSITION FLOOR BOX SUCH THAT THE TOP OF THE COVER IS FLUSH WITH THE TOP SURFACE OF THE CONCRETE FLOOR SLAB. PROCURE A SECOND COVER TO REPLACE THE ORIGINAL COVER USED DURING THE CONCRETE POUR AND ROUGH-IN WORK, AND INSTALL SECOND COVER JUST PRIOR TO THE INSTALLATION OF CARPET OR AFTER FLOOR GRIND/POLISH. REMOVE ANY CONSTRUCTION DEBRIS AND DUST. AFFIX GASKET TO UNDERSIDE OF COVER TO PERMIT PROPER GASKETED INSTALLATION. WHERE A FLOORING MATERIAL IS APPLIED TO THE SURFACE OF THE SLAB (CARPET, TILE, ETC.) ALSO APPLY THE MATERIAL TO THE COVER OF FLOOR BOX, WITH OPENINGS TO ACCESS THE SCREWS IN THE COVER.
10. THICKEN THE SLAB AS REQUIRED UNDER THE FLOOR BOX FOR STRUCTURAL REINFORCEMENT.
11. IF THE PLAN DRAWINGS SHOW OUTLET WITH CONDUIT, PROVIDE CONDUIT. DO NOT USE THE WIRE BASKET TO ROUTE CABLING, ESPECIALLY THROUGH PLENUM-RATED SPACES.

3.5.2.5 TELECOMMUNICATIONS OUTLETS FOR SPECIAL INDOOR APPLICATIONS

- A. IP video surveillance camera applications shall be provided one Category 6A cable each, terminated near the desired camera location.
 - Mount the data outlet between 12" and 24" above accessible ceiling tiles or above the lighting plane of an exposed ceiling.
 - For hard-lid (gypboard) inaccessible ceilings, provide a downward-facing 5" square x 2.875" deep box in the ceiling with a faceplate accessible from the underside of the ceiling.
 - Provide a single gang extension ring and faceplate.
 - Use a patch cord to connect the camera to the jack in the data outlet.
- B. An ADA-compliant courtesy telephone may be required in a main floor gathering space. The Designer shall inquire with the Architect and Clemson FPM whether courtesy telephones are included in the project and shall design a wall-phone outlet for each location.
- C. A two-way communications device is required in each elevator landing except for the story of exit discharge, as required by IBC 1007.8. The Designer shall coordinate with the Architect about the specific location where the devices shall be mounted in each landing area.
- D. The following table lists several special applications and the corresponding provisions for voice, data and power:

Application	Conduits	Telecom	Power
Vending Machines	one 1¼"	1 cable per machine	1 single gang receptacle with dedicated circuit per machine
Point of Sale Counters (Retail)	one 1¼"	3 cables	1 double gang receptacle per station
Point of Sale Counters (Residential)	one 1¼"	2 cables	1 double gang receptacle per station
Touch Screen Kiosks	one 1¼"	1 cable per machine	1 single gang receptacle per pair of kiosks
Instructors Console	Inquire with AVTL	Inquire with AVTL	1 double gang receptacle
Courtesy Telephones	one 1¼"	1 cable	N/A
Digital Signage (Flat Panel Display + Digital Media Player)	one 1¼"	2 cables	1 single gang receptacle
Televisions	one 1¼"	2 cables	1 single gang receptacle
Ceiling-mounted Projectors	one 1¼"	Up to 6 cables	1 double gang receptacle
Conference Room A/V Junction Wall Box	Inquire with AVTL	4 cables	1 single gang receptacle
Lighting Control System Main Panel	one 1¼"	1 cable	N/A

- E. Outlets mounted in raised floor applications may be fed from consolidation points. Provide 2 cables to each outlet from the consolidation point, with a maximum of 48 cables per consolidation point.
- F. Outlets shall be provided to connect power monitoring equipment to the network. Clemson uses Category 6A cabling for these applications.
- G. Outlets will be required in mechanical and electrical spaces to provide network services to mechanical control equipment, electrical power monitoring equipment, and lighting control panels. The Designer shall address these needs on a project-by-project basis.
- H. The following applications require case-by-case direction. The Designer shall work with the the Clemson FPM and NSTTL to determine the appropriate solutions for these applications:
 - Fire alarm panels
 - Elevators
 - Security systems
 - Access control systems
 - Security systems
 - Security scanning stations
 - Point-of-sale equipment
 - ATM Machines
 - Irrigation controllers
- I. Clemson considers undercarpet telecommunications cabling (UTC) solutions to be **prohibited**. In lieu of undercarpet cabling, the Designer shall consider the Connectrac product line.
- J. Structural backing shall be designed into walls to support wall-mounted equipment. See the manufacturer’s guidelines for each piece of wall-mounted equipment. The Designer shall discuss this topic with the NSTTL.
- K. The Designer shall inquire about the requirements for any special design considerations, including compliance with the Architectural Barriers Act Accessibility Standard (ABAAS).

3.5.2.6 OUTDOOR WIRELESS ACCESS POINTS AND SURVEILLANCE VIDEO CAMERAS

Outdoor gathering spaces shall be designed to have wireless network coverage. Outdoor-rated outlets may be required to serve outdoor wireless access points and outdoor surveillance video cameras.

3.5.2.6.1 POLE-MOUNTED

For pole mounting applications, Clemson has been using equipment from CommScope, Cisco, and Axis as shown in the image at right. The Designer shall incorporate the following features using these specific manufacturers or pre-approved equal equipment:

- Commscope Powered Fiber
- POE+ Extender
- Wireless Access Point
- Lightning protection (surge suppression)
- Camera and housing
- Vandalism protection
- Aesthetic integration
- Headend equipment

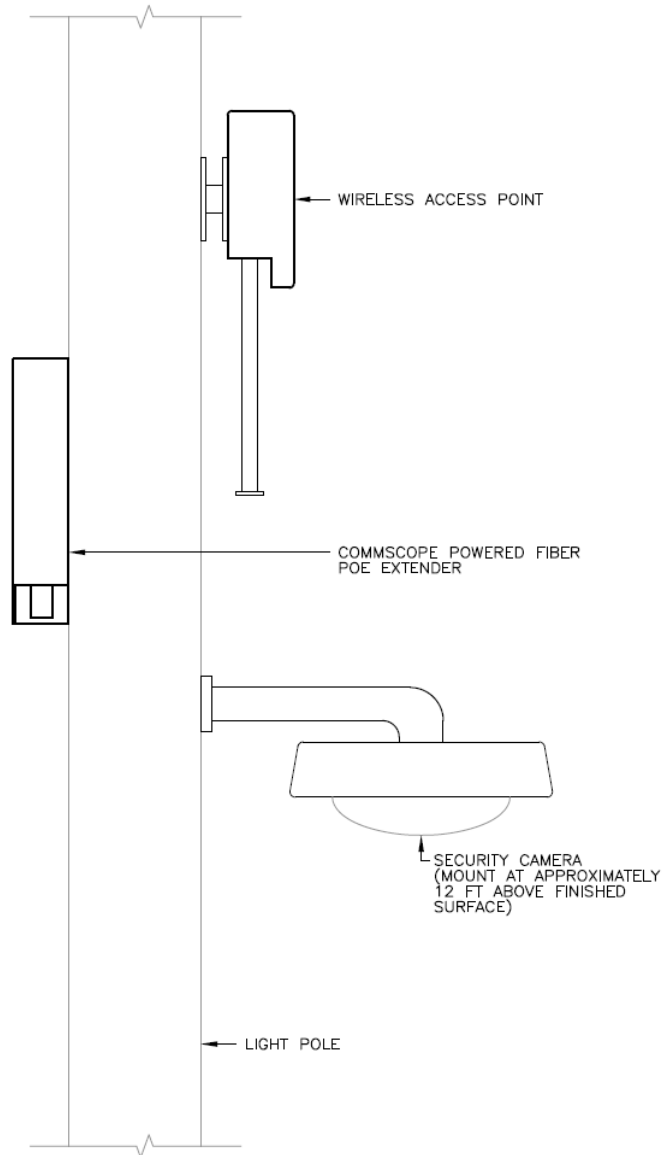

3.5.2.7 WORKSTATION POWER OUTLETS

A. There shall be at least one general-purpose convenience power outlet (120VAC, 20 Ampere minimum) located within three feet of every telecommunications outlet. The Designer shall discuss any application-specific needs with Clemson NST staff and adjust the power outlet locations and amperage accordingly.

- For new construction projects and modernization projects, the power outlet associated with each telecommunications outlet shall be a 4"x4" device box (dual gang) with four 5-20 receptacles (a quad power outlet). It is the Designer's responsibility to coordinate with the Electrical Engineer to ensure that power outlets are located near telecommunications device boxes.
- For minor remodel, historical building remodel, and telecommunications-only projects, it may be difficult to meet this requirement. Therefore, where existing power outlets are not located within six feet of each telecommunications outlet, the Designer shall alert the NSTTL and request consideration of the situation on a case-by-case basis.

3.5.2.8 DEPARTMENTAL-SPECIFIC APPLICATIONS

Many organizational and operational departments at Clemson have technology infrastructure applications that are specific to that department. During the course of a project, the Designer shall inquire with the FPM and the NSTTL about whether each of the following features apply to that project:

3.5.2.8.1 HOUSING AND DINING

- Public spaces may require workstation outlets for student use and equipment in public spaces, including printers, televisions, digital signage, etc.
- Residence Halls are almost entirely wireless. However, a single wired connection is required in each living space to support a wall-mounted wireless access point. In Residence Halls serving students studying technical fields (such as engineering), three additional cables run from the wireless access point to jacks near desks for student use.
- In Residence Halls, wired telephones and network are required for offices and in staff apartments.
- Security cameras, Point-of-Sale counters, punch card machines for employees, and time clocks require telecommunications cabling.
- Access control card readers are mostly wired; however some are wireless. The decision needs to be made early in a project whether to use wired POE (preferred) to each access control door application or whether to use wireless.
- Networked printers require 2 data jacks (one for the printer and one for the payment system).
- The alarm system in elevators requires telecommunications cabling.
- In Residence Hall laundry rooms, the washer/dryer system requires one network connection to support a smartphone app that alerts students to let them know their laundry is done.
- Provisions on Demand (POD) vending machines and ATM machines require network connections.
- Lighting control panels require a network connection for centralized monitoring.
- Conferences and summer sports camps use residence hall spaces. Some special cabling applications might be required to support these events.

3.5.2.8.2 PARKING SERVICES

- The Site Lighting and Street Lighting systems require one outdoor-rated network cable to the first light pole. The network then continues wirelessly to other nearby light poles.
- Parking lot entry and control point (swing-arm) gates require networking for monitoring.
- Security cameras and license plate recognition cameras require network cabling.
- Self-service parking meter kiosks require network cabling for credit card processing and reporting.

3.5.2.8.3 TWO-WAY COMMUNICATION DEVICES FOR ELEVATOR LANDING

Clemson wishes to use simple stand-alone two-way communication devices (as opposed to devices that network to a headend).

3.5.2.8.4 SECURITY CAMERAS

At Clemson, security cameras require wired network cabling for video over IP with POE+ as the power source.

3.5.2.8.5 AUDIO/VISUAL

- The Audio/Visual (A/V) industry is rapidly converging with Ethernet, and almost all A/V equipment is hard wired and POE.
- The instructor lectern and A/V equipment racks require a large amount of network cabling.
- Some A/V features use wireless networking to share video content from personal devices.
- HDBaseT is used at Clemson, requiring Category 6A cabling. However, Dante use is more rare.
- Sometimes A/V equipment will be located in the telecom room. Its location depends on where the telecom room is relative to the application space.
- Digital signage requires two network cables; one to network the small PC behind the video panel, and the other for the video panel itself.

3.5.2.8.6 ATHLETICS DEPARTMENT

- Point of Sale stations need three network cables per POS location, with potentially 5 registers on one service counter (register, credit card terminal, and TigerOne scanner).
- Many non-athletic events are held at Athletics facilities. This requires additional cabling to support temporary uses.
- Distributed Antenna Systems (DAS) are funded by Verizon and AT&T. Clemson provides space for the equipment and a route to the roof for antennas.
- Permanent broadcast camera stations communicate via fiber. The signal is an AV signal on the fiber, and is converted to packetized Ethernet at the head end.
- Digital signage usage is steadily increasing. Airmark handles digital signage systems, having one cable at every display and countertop.
- One network cable is required per vending machine.
- Handheld ticket scanners use WiFi.
- TV truck locations require permanent cabling with umbilical fiber optic and copper cables.

3.5.2.8.7 SECURITY

- Mass notification systems are required inside buildings.
- Telecommunications room doors require access control.

3.5.2.8.8 BUILDING POWER MONITORING

- Use PowerLogic power meters, at a minimum one per building in the main electrical room. A single network cable is required at that location.
- On a case-by-case basis, it is possible that sub-metering might be desired, requiring one network cable per metering location.

3.5.2.8.9 MECHANICAL SYSTEMS

- Chilled Water
- Steam
- Potable Water
- HVAC Metasys

3.5.2.8.10 ACADEMIC

- Lighting Control
- Room Scheduling

3.5.2.8.11 OTHER

- ATM Machines
- Bluelight Emergency telephones
- Security cameras
- Electric vehicle charging station

3.5.2.8.12 FIRE ALARM SYSTEM

For each Simplex fire alarm control panel (FACP) location, provide a red-jacketed 2-strand singlemode cable from the fiber optic patch panel in the MDF (LC-duplex) to a small splice tray mounted inside the FACP. At the splice tray, splice on a 2-strand pigtail with duplex SC or ST connectors. Late in the design process, the Designer shall inquire with the fire alarm system designer or contractor whether SC or ST connectors will be required.

- If the fiber will route exposed through outdoor spaces or through spaces that are accessible to bats (such as attic spaces) provide Corning Armored MIC fiber optic cabling and terminate the armor with an MC connector in knockout in the FACP sidewall.
- Otherwise, provide Corning MIC cable via cable tray and red-painted conduit raceways. If the fiber will route via J-hook pathway, provide innerduct to support the cabling.
- Do not use Angle Polish Connectors (APC).

Some of the buildings on campus have fire alarm system panels that use alarm dialers, requiring two Category 6A cables and two analog telephone circuits for each application.

Fire alarm panels for all new buildings off-campus will use a dialer, and may be from a manufacturer other than Simplex.

3.5.2.8.13 EMERGENCY PHONES, ELEVATOR PHONES, AND AREA OF REFUGE PHONES

- Elevator landings and areas of refuge require a 2-way communication device.
- Emergency communications devices shall be programmed to route calls directly to the Clemson University campus police department at 656-2222.

3.5.2.8.14 LIGHTING SYSTEM

As a prototype project, Clemson has constructed one building that uses POE driven lighting. Clemson may decide to construct future buildings with this feature. If so, approximately three 48-port patch panels and three 48-port POE network electronics would be required for each floor of a building.

3.5.2.8.15 EMERGENCY RESPONDER RADIO DAS

800MHz radios are used by emergency responders. Future buildings may require internal distributed antenna systems (DAS) to distribute these signals.

3.5.2.8.16 TELEPHONE SYSTEM

- VOIP telephones are being installed now instead of traditional telephones.
- While VOIP is not normally considered by Clemson to be a life safety system, it is considered to be operationally critical for some applications. See Section 3.3.9.1 for additional information.

3.5.2.8.17 MASS NOTIFICATION SYSTEM

- Clemson is in the process of developing its solution for mass notification system on campus. The Designer shall inquire with the NSTTL about how mass notification should be handled on a project-by-project basis.
- Clemson has an existing set of sirens on campus to provide a warning when lightning strikes are a threat.
- Clemson is considering ways to integrate projector screens in the stadium and also digital signage into a mass notification system.
- The campus uses the “Alertus” service to distribute emergency information.

3.5.3 HORIZONTAL CABLING SYSTEMS

3.5.3.1 GENERAL

- A. The Designer shall work with the Clemson FPM and the NSTTL to identify and understand the needs and requirements for the facility on a project-by-project basis. This includes understanding the expected future uses of the facility. The Designer shall design the horizontal cabling accordingly.
- B. The Designer shall inquire with the NSTTL at the start of each project to determine whether a traditional (Category 6A) telecommunications infrastructure shall be designed.
- C. Telecommunications infrastructure designs and specifications shall be based upon products from approved manufacturers, as defined in TDDG Section 1.6 *Required Manufacturers (Basis of Design)*, above.
- D. In addition to the manufacturers listed above, Clemson has selected several manufacturers of products for telecommunications cabling systems (cable, connectors, termination blocks, patch panels, etc.) and telecommunications

distribution hardware (racks, cable tray, enclosures, etc.). The Designer shall incorporate only these manufacturers into the design, and shall design a telecommunications distribution system that will be suitable for the use of products from these manufacturers.

- E. Whenever moves, adds, or changes (MAC) are made to existing systems, the new cabling shall follow the routes of existing established telecommunications cabling pathways.

3.5.3.2 TOPOLOGY

Clemson has standardized on the star topology for all horizontal cabling, with some exceptions for certain building automation systems that require or benefit greatly from ring or other topologies.

3.5.3.3 HORIZONTAL DATA APPLICATIONS

- A. At Clemson facilities, horizontal distribution copper cable and components for data applications shall be rated for and installed in compliance with the IEEE 802.3ab 10GBase-T standard. Clemson requires 4-pair, unshielded twisted-pair (UTP) copper Category 6A-rated cabling for all horizontal data cabling applications.
- B. Horizontal cables shall be terminated at the work area end and patch panel end with modular jacks.
- Clemson has standardized on the color **blue** for horizontal data cabling.
 - Category 6A cabling is used for intra-building riser/backbone, and it shall be **white**.
 - The color of the modular jack shall be **orange** at the faceplate and **black** at the patch panel.
- C. In existing buildings, where additions are made to an existing installation, use Category 6A cable and matching components.

3.5.3.4 HORIZONTAL FIBER OPTIC CABLING APPLICATIONS

Any horizontal applications requiring fiber optic cabling (such as fire alarm control panels, power monitoring equipment, etc.) shall be served from the MDF. In other words, all such applications shall be cabled directly from the MDF, regardless of the floor on which they are located.

- Fire alarm control panels require two strands of singlemode fiber optic cable. See Section 3.5.2.8.12 for additional information.

3.5.3.5 GPON HORIZONTAL CABLING SOLUTION

Clemson is currently constructing its first GPON application on campus based on cabling from Commscope and GPON equipment from Nokia. It is anticipated that with

experience operating the GPON infrastructure, Clemson will gain insight about how best to apply this architecture for future projects.

3.5.3.5.1 GPON ARCHITECTURE

- A. The architecture for GPON at Clemson is currently an unsettled topic. Based on a single GPON project at Clemson, the current architecture can be described as follows:
- The optical line termination (OLT) equipment shall be located in the campus data center.
 - Outside plant backbone fiber optic cable shall connect the building MDF to the campus data center. At least 2 strands of OSP fiber per splitter are required.
 - 2x32 splitters should be used throughout the system.
 - Splitters should be located in the MDF and IDFs, and should be mounted in the Corning fiber optic patch panels (alongside fiber optic cabling terminations).
 - Single-strand singlemode fiber optic cables should run from Corning fiber optic patch panels in the telecommunications rooms to each outlet.
- B. The Designer shall inquire with the NSTTL about GPON topology and discuss options for Clemson's consideration prior to committing the design to a particular topology.

3.5.3.5.2 ACADEMIC AND ADMINISTRATIVE BUILDINGS

- A. The Designer shall inquire with the Clemson NSTTL to obtain instructions regarding the number of ONT ports to allocate to each office, workstation, and to other applications.
- B. The Designer shall inquire with the AVTL for instructions regarding the number of ONT ports to allocate to audio/visual applications, such as the instructor podiums in classrooms and the audio/visual equipment racks in conference rooms.

3.5.3.5.3 RESIDENCE HALLS

- A. The Designer shall inquire with the NSTTL whether the telecommunications infrastructure for new residence halls projects shall be designed as GPON systems, and whether television distribution shall be carried via GPON.
- B. The Designer shall inquire with the Executive Director of Clemson Housing and Dining to get instructions regarding the number of ONT ports to allocate to each person, room, or apartment space in each residence hall.

3.5.3.5.4 OUTLETS

All GPON outlets, regardless of application, shall be designed with a single strand of singlemode fiber optic cabling, and shall use factory-terminated cables.

3.5.3.5.5 CABLE TRAYS

While GPON solutions typically require less cable tray capacity than traditional systems, the Designer shall design cable trays such that are appropriately sized for traditional infrastructure (larger than GPON would require).

3.5.3.5.6 INNERDUCT FOR GPON APPLICATIONS

- A. The Designer shall show on the Contract Documents where innerduct is required for routing GPON fiber optic cabling, in accordance with the following conditions:
 - Innerduct is required for routing GPON fiber optic cabling through non-horizontal pathways (such as riser conduits and sleeves) that exceed 4 feet in length, and which will be shared with non-GPON cabling.
 - Otherwise, innerduct is not required for routing GPON fiber optic cabling.
- B. See Section 3.4.3.1.9 regarding innerduct requirements for outside plant fiber optic backbone cabling.

3.5.3.5.7 ONT INSTALLATION

Clemson requires that the Contractor furnish, install, and power up the optical network terminal (ONT) devices at each workstation, and also verify that the data link light is active. The Contractor shall also be required to provide a spreadsheet report that correlates the ONT's FSAN identifier with the outlet number, room name, and room number.

- The Designer shall include this requirement in the Contract Documents.

Clemson will configure the ONT devices after the Contractor has established successful operation of each ONT.

3.5.3.5.8 WIFI AND CAMERA APPLICATIONS

- A. Where multiple wireless access point and camera devices share an ONT, a ceiling box shall be provided in the ceiling near the zone where the devices are located. The ONT shall be mounted inside this box, along with the fiber optic outlet and a power outlet. Some of the devices sharing the ONT may require a conduit in the wall and a box at standard mounting height for copper patch cords to route down from the ONT in the ceiling.
- B. In smaller buildings, or where there are a lower density of wireless access points, an alternative is to supported them with Category 6A in a traditional telecommunications architecture in parallel with GPON. Rack-mounted ONTs should be used to provide POE network connections to the access points.

3.5.3.5.9 ANALOG CIRCUIT APPLICATIONS

- A. For the analog telephone applications supporting life-safety systems, provide a Category 6A cable from the nearest telecommunications room containing an analog gateway device. See Section 3.3.9.1.1 for additional information. Do not

use GPON for the following:

- Telephone circuits for 2-way communication devices in elevator lobbies and areas of refuge
 - Telephone circuits for elevator phone
 - Telephone circuits for fire alarm panels
- B. For all other analog telephone applications, including fax machines, use a nearby GPON ONT to obtain a POTS connection.
- C. Ensure that all GPON applications comply with NEC requirements.

3.5.3.5.10 TELECOMMUNICATIONS ROOM SIZING FOR GPON APPLICATIONS

- A. For buildings being designed with GPON solutions, the main telecommunications room (MDF) shall comply with the same size requirements as buildings with traditional telecommunications infrastructure.
- B. Clemson has not yet determined guidelines for sizing secondary telecommunications rooms (IDFs) in buildings being designed with GPON solutions. The Designer shall inquire with the Clemson NSTTL to determine the IDF sizing strategy for a given project.

3.5.3.6 HORIZONTAL VOICE APPLICATIONS

- A. Clemson makes no distinction between a cable to be used for a data application versus one intended for a voice application. Whether the voice application is VOIP or analog, the horizontal cable supporting it shall be the same cabling materials as a data network application.
- B. The following are several examples of horizontal voice applications. The Designer shall inquire with the NSTTL and the Architect to determine which of these are required for a given project:
- Elevator emergency telephone circuits
 - Outdoor Blue-light emergency telephones
 - Wall-phone outlets
 - Area of Refuge two-way communication telephones
 - Elevator lobby two-way communication telephones
 - Alarm dialing circuits for fire alarm control panels
 - Hardened courtesy telephones

3.5.3.7 LOW-VOLTAGE AND BUILDING AUTOMATION SYSTEMS

- A. During planning for intra-building telecommunications cabling installations, the Designer shall identify options for supporting power-limited (low-voltage) and building automation systems with the common structured cabling system, and present the options to Clemson for consideration. These options shall comply with ANSI/TIA/EIA 862 – Building Automation Systems Cabling Standard for

Commercial Buildings.

- B. By providing a common cabling distribution system for the various building automation systems, it may be possible to reduce construction costs and operational costs while creating an intelligent building that can contribute many other benefits (see TDM Chapter 14 *Building Automation Systems* for additional information). Low-voltage systems that are capable of using a common structured cabling system (either backbone or horizontal cabling) shall be designed to use telecommunications cable and termination hardware wherever possible. See also Section 3.14 *Building Automation Systems* for additional information.
- C. The Designer shall request from Clemson a list of systems that will require telecommunications outlets for operations. The Designer shall then include horizontal cabling in the design as necessary to meet the listed requirements.
- D. All low-voltage devices (cameras, access control, etc.) and building automation equipment requiring network connections shall have cabling terminated in a jack and faceplate, with a patch cord connecting the device to the jack.
- One industry-accepted solution for horizontal telecommunications cabling intended for use with permanently mounted equipment is detailed in the new standard ANSI/BICSI 005-2016 - *Electronic Safety and Security (ESS) System Design and Implementation Best Practices*. This standard permits horizontal cabling to be terminated on the device end of the cable using a connector (as opposed to a jack) allowing the horizontal cable to plug straight into the device.
 - While the industry permits this solution, Clemson University does not wish to deploy this method. Do not field-connectorize horizontal cabling at the device end. Instead, as in all other horizontal cabling applications, terminate horizontal cable on a jack in a faceplate and use a patch cord to connect the field device to the jack.
- E. Other low-voltage and building automation equipment uses terminals that require the cable to be terminated directly onto the equipment without using a modular jack. There is no method of testing a cable in this configuration.
- This application is not standards-compliant, and is unlikely to be approved by the NSTTL.
 - In most cases, it is possible to terminate the horizontal cable in a standard outlet inside a panel, field-manufacture a half-patch cord to plug into the outlet, and then terminate the raw end of the half-patch cord directly onto the terminals of the equipment.

3.5.3.8 HORIZONTAL CROSS-CONNECT (HC)

All Category 6A horizontal cabling serving a data application shall be terminated on a rack-mounted patch panel.

3.5.3.9 PHYSICAL SEPARATION REQUIREMENTS

There are currently no Clemson-driven applications or procedures that require certain cables to be physically segregated from other cables. The only expected source of such a requirement would come from a regulatory authority. The Designer shall consider whether any such regulations exist when designing cabling applications for Clemson.

3.5.3.10 PATCH CORDS

- A. The Designer shall inquire with the NSTTL to determine whether patch cords will be provided by the contractor or by the Owner, or some combination of both. The Designer shall work with the NSTTL to quantify and specify the required patch cords for each particular project.
- B. Patch cords with a bootless connector shall be factory-manufactured by the SCS manufacturer. Patch cords shall be certified by the manufacturer to match the cable type used in the backbone or horizontal distribution.
 - Field-connectorized patch cords are not acceptable. Any existing field-connectorized patch cords used in areas affected by a project shall be replaced under the project with factory-manufactured patch cords.
- C. See Appendix 5.1 for a diagram that depicts Clemson's standard patch cord colors.
- D. The Designer shall inquire with the NSTTL about whether the Contractor shall perform the following tasks:
 - Install all patch cords in the telecommunications rooms.
 - Install all patch cords to special applications outside of telecommunications rooms. This includes routing patch cords through system furniture.
 - Install computer and telephone patch cords at workstations.

3.5.4 HORIZONTAL PATHWAY SYSTEMS

The process of selecting the type of pathway that would be appropriate for a particular project shall be a cooperative effort involving the Designer and the NSTTL.

3.5.4.1 GENERAL PATHWAY DESIGN CONSIDERATIONS

- A. All cables shall be fully supported and properly transitioned throughout their lengths, including proper bend radius fittings at pathway transitions. Where cabling is routed vertically, it shall be appropriately secured such that the weight of the cabling does not subject the cabling to stresses that could potentially reduce the performance of the cabling.
- B. Clemson prefers generally to use a combination of cable tray, conduits and junction boxes for all telecommunication and other low-voltage pathways.

- C. The Designer shall discuss pathway type and size options with the NSTTL.
- The Designer shall discuss the relative merits of the pathway options available and shall assist the NSTTL and the project design team to select the most appropriate pathway solutions for the project.
 - The future growth anticipated for the facilities affected by the project shall be discussed. Horizontal feeder pathways (cable trays, conduits from TRs to distribution junction boxes) shall be sized to support the initial cabling installation plus a minimum of 50% growth.
 - J-hook pathways are only acceptable when approved by the NSTTL.
- D. Spare pathway shall be designed to terminate at building perimeters where future expansion of the building is anticipated.
- E. When considering the design of a ceiling-located cable tray, the Designer shall verify that the pathway locations will comply with accessibility and clearance requirements. Cable tray routed through ceiling spaces shall be designed such that all installed cable is conveniently accessible after construction, both for cable maintenance and to install subsequent cable additions. Conduit shall be used to span inaccessible areas where the pathway will cross “hard-lid” ceilings, where ceiling tiles are not readily removable, or where accessibility is impeded.
- F. Pathway routing shall remain on the same floor as the telecommunications room and telecommunications outlets served by the pathways. Where project-specific conditions exist that justify other routing, the Designer shall request Clemson approval through the SVR process.
- G. “Poke-thru” penetrations to the ceiling space of the floor below are normally not permitted. For minor remodel construction, poke-thru penetrations may be allowed given budgetary, project size, or other limiting factors. Permission to use poke-thru pathways in any circumstance requires an SVR on a project-by-project basis, and always requires the services of a structural engineer to avoid irreparable structural damage.
- H. All wall and floor penetrations for cabling shall be fully sleeved with bushings, and protected in accordance with the requirements in the International Building Code.
- I. For on-grade slab construction, telecommunications conduits shall not be routed in or under the slab (a designated wet environment) unless no other options exist.
- Floor boxes under conference tables in Meeting Rooms and under Teacher Stations in Classrooms are exceptions to this requirement.
 - In any application (including Meeting Rooms and Classrooms) where telecommunications conduit passes in or under an on-grade slab, outdoor-rated cabling shall be provided.

3.5.4.2 PATHWAYS FOR NEW CONSTRUCTION AND MODERNIZATION PROJECTS

- A. Where ceiling spaces will be inaccessible after construction, the only permitted pathway option is conduit.
- B. Surface raceways and surface-mounted device boxes are not permitted.
- C. J-hook pathways are not permitted.

3.5.4.3 PATHWAYS FOR MINOR REMODEL AND TELECOMMUNICATIONS-ONLY PROJECTS

- A. For minor remodel construction, there may not be an existing (or suitable space for a new) telecommunications room available on the same floor as an outlet. While pathways shall generally be designed from the device box serving the telecommunications outlet to the nearest telecommunications room on the same floor as the outlet, this requirement may be waived by the NSTTL.
- B. Existing pathways shall be reused where existing raceway is standards-compliant or where it can be verified that the existing pathway will permit telecommunications cabling to be installed without negatively affecting the performance of the cabling. Where a pathway is concealed or cannot otherwise be verified, the Designer shall request direction from the NSTTL on a case-by-case basis.
- C. Where existing pathways cannot be reused, or where additional pathways are required:
 - J-hook pathway may be used. D-ring and bridal-ring pathways are not permitted. J-hook pathways shall be established through concealed spaces. J-hook pathways shall be sized for a minimum of 50% expansion.
 - When 30 or more cables are designed to be routed through an area, the use of cable tray or conduit shall be considered in lieu of J-hooks.
- D. It may be permissible to use faceplate mounting brackets in lieu of device boxes. In these cases, cabling is routed to the outlet location through interstitial wall spaces. Clemson permission for this method is required on a project-by-project basis.

3.5.4.4 CABLE TRAY PATHWAY SYSTEMS

- A. In general, cable tray systems shall be located in corridor or office throughway spaces, and shall not be installed above office or classroom space. Distances from EMI/RFI sources shall be maintained according to Section 3.2, *Electromagnetic Compatibility* (above), regardless of whether the raceway is routing copper- or fiber optic-based media.
- B. Clemson prefers that cable trays be concealed above accessible ceiling spaces and that wire basket type tray be used when concealed. Where cable trays are visible to the public (not concealed), the Designer shall work with the architect to specify cable tray materials, paint and a design concept that will not detract from

the appearance of the building.

- Ladder racking shall be used only in telecommunications rooms. It shall not be used anywhere else.
- Spine-style tray is not acceptable.

Wire Basket Tray



- C. For main distributions (corridors) 12" x 4" tray is the minimum allowable size. The Designer shall design cable tray that is filled to no more than 50% of its allowable rating on Day 1.
- D. A continuous ground conductor shall be run the length of the cable trays, and shall terminate on the telecommunications grounding busbar in the telecommunications room. Each segment of cable tray shall be bonded to this conductor with a bonding lug. Even though most cable tray manufacturers offer solutions to use the tray as a grounding conductor, those solutions shall not be used at Clemson.
- E. Telecommunications cable trays shall not be shared with power cables.

- F. When cable tray is wall-mounted, the contact points for each mount shall be reinforced. The diagram at right depicts a possible solution for reinforced wall mounts:

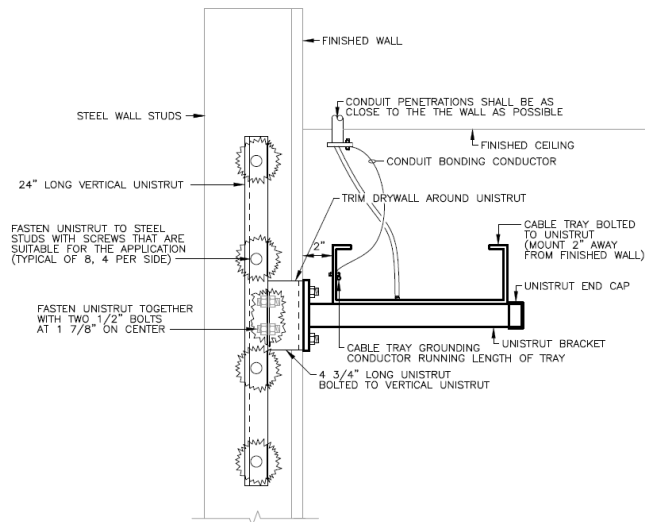

The diagram at right depicts a detailed view of the point of wall-mount attachment:

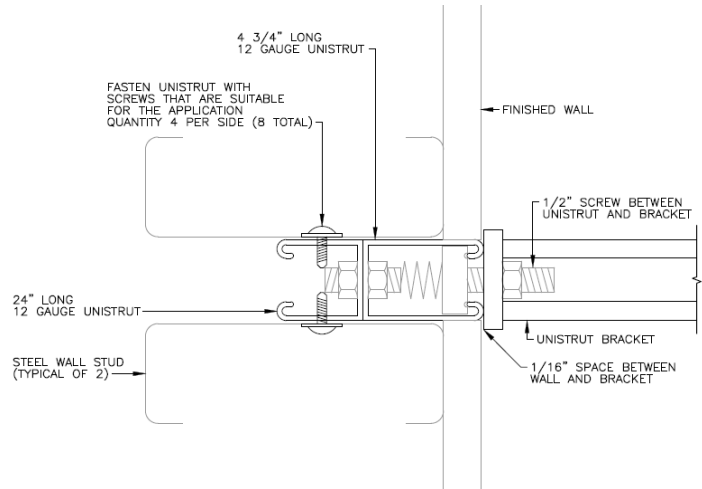

When cable tray is ceiling-hung, use trapeze-style supports. The diagram at right depicts a possible solution:

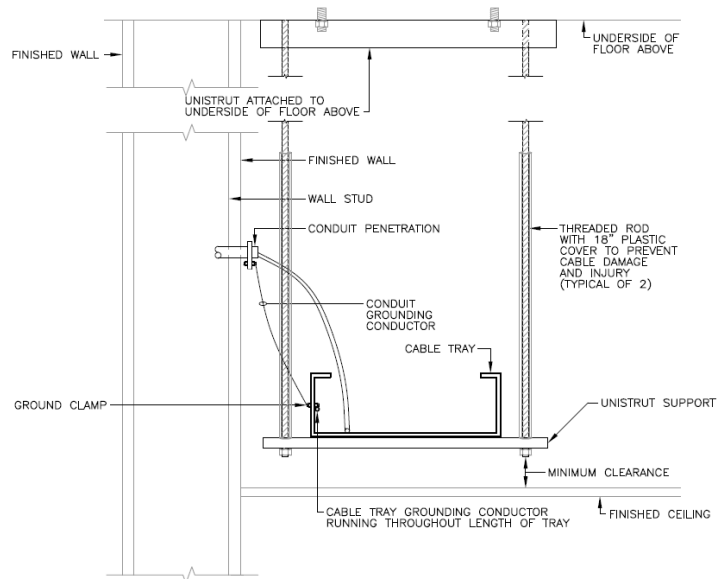

3.5.4.4.1 CABLE TRAY CLEARANCES

Clemson uses cable trays to distribute cabling throughout its buildings. Cable trays shall be installed in corridors or other accessible spaces. Ceilings below cable trays must be accessible. Hard-lid/gypboard ceilings prevent access to cable trays.

Do not design cable tray routing above offices or classrooms.

To preserve access to the cable trays post-construction, the Designer shall coordinate the routing of cable trays through ceiling spaces with the designers of mechanical systems and other electrical systems, incorporating the tray into the project's BIM model. The design shall also be coordinated with the architects designing ceiling spaces. The minimum space required for cable tray along the entire length of main corridor ceilings is:

- A minimum clear space of 12 inches adjacent to the side of the cable tray, to allow technicians to stand next to the tray (on a ladder) and add or remove cabling.
- A minimum clear space of 10 inches (head height) above the cable tray, to allow for cables to be added or removed from the tray.

As shown in the diagram below, if a 12"x4" cable tray were used, the minimum overall cross-sectional area for and the associated working space is 24" wide x 14" high.

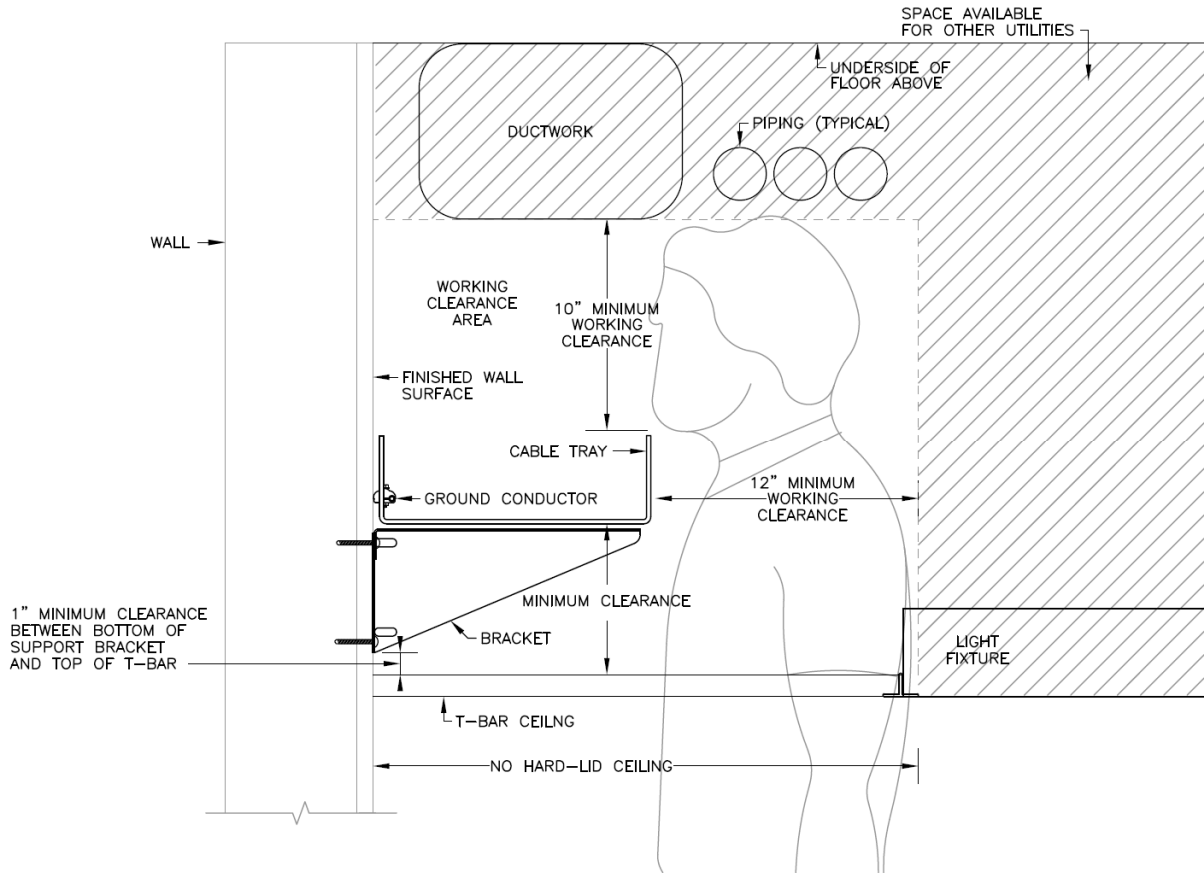

Occasional obstructions to the cable tray are permissible as long as access to the tray (as depicted above) is restored within 36" (arm's reach).

3.5.4.4.2 GENERAL PATHWAY DESIGN CONSIDERATIONS

- A. All cables shall be fully supported and properly transitioned throughout the length of the cables, including proper bend radius fittings at pathway transitions. Where cabling is routed vertically, it shall be appropriately secured such that the weight of the cabling does not subject the cabling to stresses that could potentially reduce the performance of the cabling.
 - Cable supports shall be installed prior to the installation of cabling. It is not acceptable to install cabling first, allowing it to hang unsupported until supports are later installed.

- B. Cabling shall be properly supported whenever it changes elevation (routes higher or lower). Whenever cabling changes elevation via a free-air gap from one raceway to another, a radius drop or waterfall fitting is required on the upper raceway. Whenever the elevation change exceeds 24", a vertical supporting raceway is required (such as a wall-mounted ladder rack, or a sloping cable tray). The following are some examples of solutions that shall be used to prevent damage to cabling during vertical elevation changes:

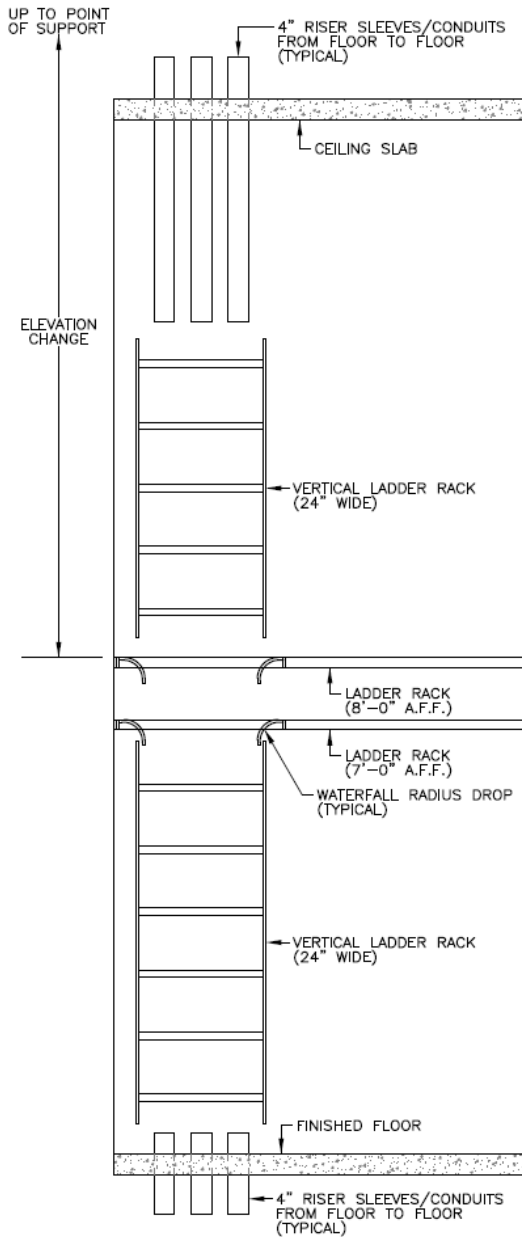

CABLE SUPPORT THROUGH ELEVATION CHANGE
RISER PATHWAY / TELECOMMUNICATIONS ROOMS

NOT TO SCALE

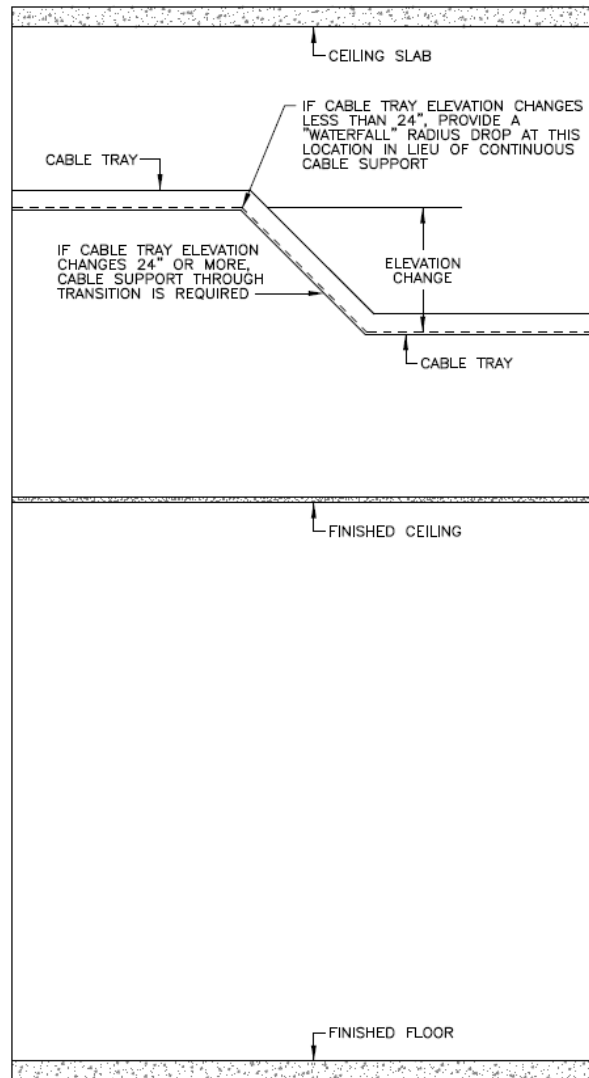

CABLE SUPPORT THROUGH ELEVATION CHANGE
CABLE TRAY

NOT TO SCALE

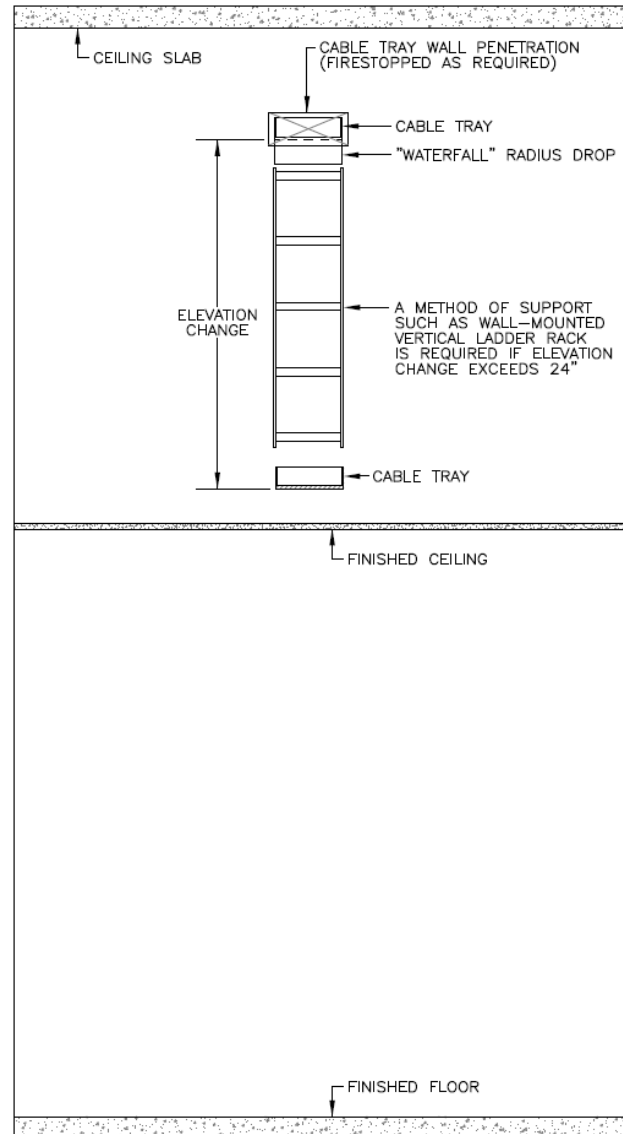
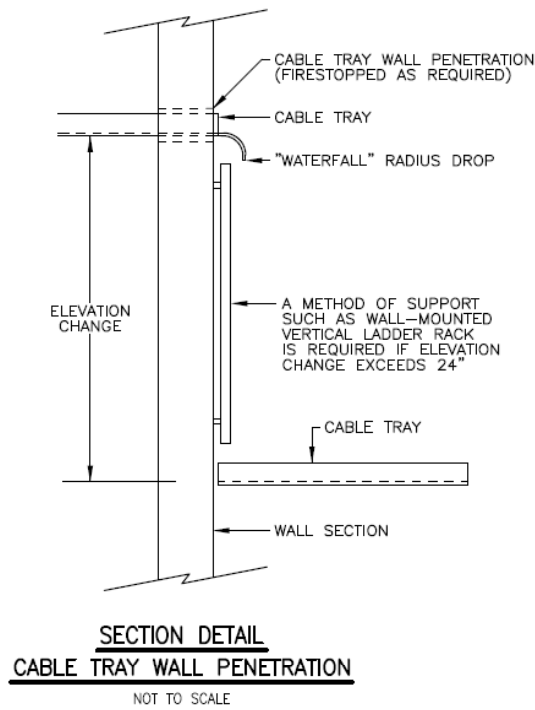

CABLE SUPPORT THROUGH ELEVATION CHANGE
CABLE TRAY WALL PENETRATION
 NOT TO SCALE

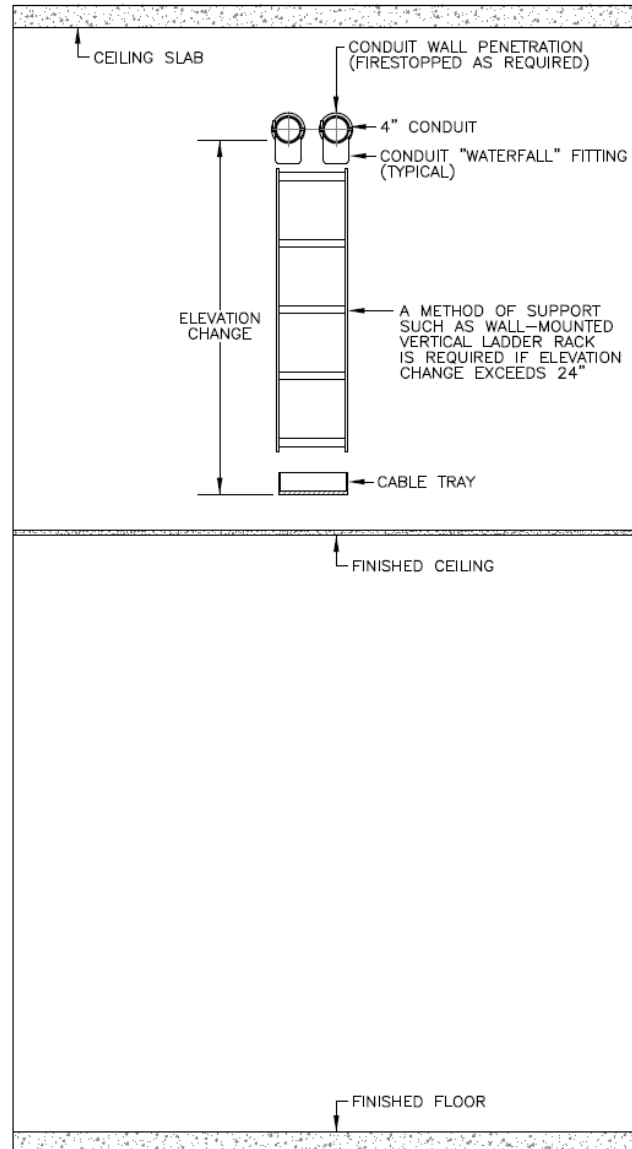
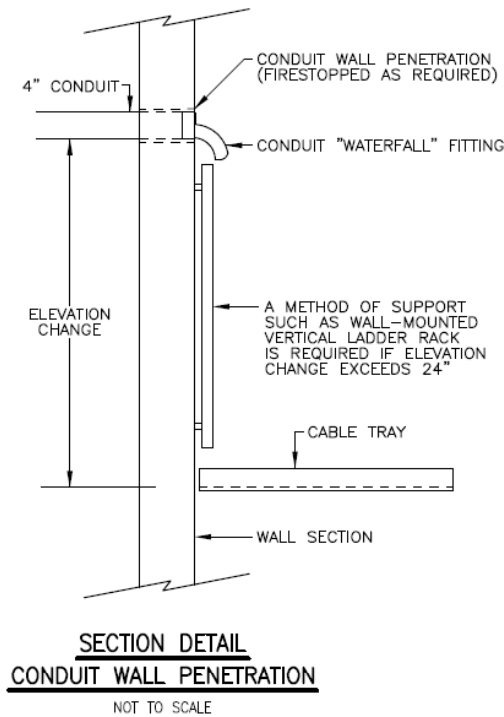

CABLE SUPPORT THROUGH ELEVATION CHANGE
CONDUIT WALL PENETRATION
 NOT TO SCALE

3.5.4.5 CONDUIT AND JUNCTION BOX PATHWAY SYSTEMS

- A. Conduits both in and under the ground floor slab are considered “wet locations” where indoor-rated cabling is not permitted. Therefore, conduit serving the main floors of such buildings shall be routed in walls and ceilings – not in or under the slab. Intra-building and horizontal pathways shall only be installed in “dry” locations where indoor cabling can be protected from humidity levels and condensation that are beyond the intended range of indoor-only rated cable.

- Floor boxes in an on-grade slab are the only permissible exception. This application also requires indoor/outdoor-rated Category 6A cabling.
- B. Where conduit runs terminate at cable trays, the conduits shall be arranged in an organized, uniform manner to facilitate an orderly cable transition from conduit to cable tray. Conduits shall terminate within a range of 3" to 18" of the cable tray.
- C. Where conduit runs terminate in telecommunications rooms, the conduits shall be arranged in an organized, uniform manner to facilitate an orderly cable transition from conduit to ladder rack.
- D. Non-metallic conduit and flex conduit shall not be used for horizontal pathways.
- E. Conduits shall not be filled beyond 40%. The Designer shall verify the outer diameter of the cabling for a project at the time of the design to determine the maximum number of cables that can be placed inside a conduit without exceeding the 40% fill limitation.
- F. All work area outlets shall have a minimum 1¼" conduit routing from the device box to an accessible cable pulling location (such as a cable tray). The conduit size shall be increased as necessary for the quantity of cables to be installed. Where new conduit is installed in existing buildings, the Designer shall notify Clemson when existing conditions prevent the use of 1¼" trade size conduit as a minimum conduit size.
- G. Device boxes shall not be "daisy-chained." Each device box shall be complete with its own dedicated conduit to the nearest distribution point/pathway.
- H. Junction boxes and pull boxes shall be oriented for access doors to open from the area where the cable installer will normally work. For ceiling-mounted boxes, this is typically from the bottom (floor) side of the box.
- I. Ceiling access to junction boxes and pull boxes shall be designed to allow full access to the door, adequate working room for the installation personnel, and proper looping of the cable during installation.
- J. Junction boxes and pull boxes shall be located in spaces that are easily accessible during normal working hours, such as hallways and common areas. Junction boxes and pull boxes shall not be located in conference rooms or offices unless there is an overriding design reason for doing so, dependent upon approval from Clemson.
- K. The Designer shall inquire with the AVTL for pathway requirements specific to audio/visual applications.

3.5.4.6 SURFACE RACEWAY

- A. Surface raceway may be permissible in areas where no suitable alternatives exist. Surface raceway shall conform to bend radius requirements for the cable type being installed.

- B. Surface raceway may be either plastic or metal.
- C. Where Category 6A (Augmented) cabling is routed through surface raceway, the Designer shall verify cable dimensions and bend radius limitations with the cable manufacturer to determine whether the surface raceway system will be deep enough.

3.5.4.7 UNDERFLOOR DUCT SYSTEMS

The design of new underfloor duct systems is prohibited.

3.5.4.8 ACCESS FLOORS

Data Centers typically require access flooring.

While some open office circumstances may require access flooring, it may be more expensive than other pathway options. When considering solutions to provide cabling in open office situations, the Designer shall consider other solutions (such as floor boxes) ahead of an access flooring solution.

3.6 ITS Cables and Connecting Hardware

Please refer to Chapter 6, *ITS Cables and Connecting Hardware* in the BICSI TDMM for information regarding the design of telecommunications cables and connecting hardware. The following requirements take precedence over the BICSI TDMM guidelines for telecommunications infrastructure at Clemson facilities:

3.6.1 COPPER CABLING

- A. Rack mounted modular patch panels and CAT6A connectors are required in the design of new telecommunications infrastructure for voice applications at Clemson facilities.
- B. The design of new telecommunications infrastructure at Clemson facilities shall not include the following termination blocks or connectors:
 - 66-style blocks or connectors
 - 110-style blocks or connectors
 - LSA-style blocks or connectors
 - 50-position miniature ribbon connectors
 - BIX style blocks

3.6.2 FIBER OPTIC CABLING

- A. Clemson uses singlemode fiber optic cabling exclusively on campus. Multimode fiber optic cabling is not used.

- B. Horizontal fiber optic cabling shall be terminated both at patch panels (bulkheads and cartridges) and at outlets using LC-style connectors with dust protection. SC, ST, and MTRJ connector types are prohibited for new fiber optic cabling terminations at Clemson facilities.
- C. Where an application requires connectors with more than two strands of fiber (high bandwidth applications, pre-terminated cables, etc.) LC connectors shall be used in accordance with manufacturer recommendations. Other connector types may be approved by the NSTTL on a case-by-case basis.
- D. Where equipment does not support LC-style connectors, the Designer shall specify hybrid patch cords with LC connectors on one end and the other end matching the requirements of the equipment.

3.6.3 SPLICING

Splicing or coupling copper or fiber optic cable is prohibited for inside plant infrastructure.

3.7 Firestop Systems

Please refer to Chapter 7, *Firestop Systems* in the BICSI TDMM for general information regarding the design of firestopping for telecommunications infrastructure. The following requirements take precedence over the BICSI TDMM guidelines for telecommunications infrastructure at Clemson facilities:

- A. The Designer shall pay careful attention to the fire ratings of existing and new walls. Wherever penetrations are made through fire-rated walls, the Drawings shall identify the firestopping requirements.
- B. Penetrations through fire-rated walls and floors shall be firestopped in accordance with the requirements of the manufacturer of the firestopping materials, and to satisfy local code enforcement officials.
- C. The Designer shall avoid design solutions calling for penetration of fire walls, fire barriers, fire partitions, smoke barriers, and smoke partitions when other reasonable cable-routing options exist.
- D. The predominant color of fire-rated pathway devices shall be orange or red.
- E. Clemson prefers to use STI Ez-Path (or a pre-approved equal alternative) for penetrations through fire-rated walls and floors. This preference is based on the experience that it is difficult to keep putty-based materials intact inside conduit sleeves, especially vertically oriented sleeves, particularly through multiple moves-adds-changes.
- F. The Designer shall reference Clemson University's Guidelines to Commissioning Architects and Engineers (the "Green Book") for instructions about firestopping at University facilities. See Section 1.1 for more information.

- G. All assemblies shall be installed in accordance with the applicable published UL designs; for instance when using an STI device or EZ-Path for a through penetration the accompanied “wall label” must be installed next to the penetration and filled out completely including the installer’s name and company information.
- H. Where required, devices that need bonding or grounding shall be completed to the manufacturer’s specifications an/or adhere to the AHJ directives.

3.8 Bonding and Grounding (Earthing)

Please refer to Chapter 8, *Bonding and Grounding (Earthing)* in the BICSI TDMM for general information regarding the design of grounding, bonding and electrical protection systems. The following requirement is in addition to the BICSI TDMM guidelines for telecommunications infrastructure at Clemson facilities:

- Grounding and bonding conductors shall be sized according to the requirements in ANSI/TIA/EIA J-STD-607D and NEC Article 250.

3.9 Power Distribution

Please refer to Chapter 9, *Power Distribution* in the BICSI TDMM for general information regarding the design of power distribution for telecommunications infrastructure. The following requirements take precedence over the BICSI TDMM guidelines for telecommunications infrastructure at Clemson facilities:

- A. The Designer shall be responsible to determine that the electrical power distribution requirements supporting the telecommunications infrastructure are met as described in this document.
- B. For projects where an electrical engineer is involved, the Designer shall coordinate directly with the engineer, and verify that the engineer’s design documentation meets these requirements. For projects without the involvement of an electrical engineer, the Designer shall alert Clemson where additional power infrastructure is needed to meet the requirements.
 - Please refer to Chapter 5, *Horizontal Distribution Systems* in the BICSI TDMM and also in TDDG Section 3.5.2 *Work Areas* for power outlet requirements for work areas.
 - Please refer to Chapter 3, *Telecommunications Spaces* in the BICSI TDMM and also in TDDG Section 3.3 *Telecommunications Spaces* for information on the power outlet requirements for TRs.
 - Clemson typically provides network electronics that provide Power-over-Ethernet.
 - The Designer shall request power consumption data for the equipment that Clemson will use, and shall size the power distribution infrastructure sufficiently to support this equipment.

- C. The Designer shall inquire which type of power conditioning/power protection equipment should be designed for each project.

3.10 Telecommunications Administration

Please refer to Chapter 10, *Telecommunications Administration* in the BICSI TDMM for general information regarding the documentation and labeling of telecommunications infrastructure. The following requirements take precedence over the BICSI TDMM guidelines for telecommunications infrastructure at Clemson facilities:

3.10.1 IDENTIFICATION STRATEGY

- A. The “identifier” is the unique name or description assigned to a given telecommunications infrastructure component. The Designer shall assign identifiers to the telecommunications infrastructure components listed below and clearly show the identifier assignments on the Construction Documents.
- B. While it is the Contractor’s responsibility to provide marked-up drawings to the Designer indicating any construction-related changes to the identifiers, the Designer shall verify that the identifiers are clearly and accurately shown on the record drawings.
- C. Telecommunications components shall **not** be labeled with an application-specific identifier. Ports shall **not** be labeled with the name or function of the device that is served by the port (server names, computer types. Also, the use of “V-#” and “D-#” are inconsistent with the industry standard-based philosophy of designing cabling systems that are independent of the application, and are therefore not permitted.
- D. The Designer shall prepare construction specifications that shall contain a comprehensive listing of the identification strategy requirements.

3.10.1.1 NEW TELECOMMUNICATIONS DISTRIBUTION SYSTEMS

The items listed below shall be shown on the Construction Documents. The Designer shall assign the identifiers to the telecommunications components based on the following required identification strategy.

- A. Telecommunications rooms, equipment rooms and data centers shall be identified as “T#” for TRs or as “M#” for MDFs, where “#” is the numerically sequential designation.

For example:

- A building with an MDF would designate that IT Space as “M1”.
 - A building with one MDF (Main Distribution Frame) and two TRs (telecommunications rooms), would have rooms labeled “M1”, T1” and “T2”.
- B. Racks and cabinets in telecommunications rooms shall have identifiers of the form “1”, “2”, etc. and would represent the sequential rack or cabinet number within a given TR.
- For example: the first rack in Telecommunications Room T1 would have the label “T1-1”, the second “T1-2” and so on.
- C. Fiber optic patch panels shall have unique indentifers provided by CCIT-NST and are in the format of FPxxxx. FP represents Fiber Panel.
- D. Ports and slots on patch panels for fiber optic cabling are typically pre-labeled by the manufacturer with sequential numbers (i.e. 1 to 12). In addition to the port labeling, each patch panel slot shall also be labeled with the cable identifier of the cable terminated at that slot. Labeling shall be in the form “###type to Far-end TR, ###-FT” where “###type” is the strand count and fiber type, “Far-end TR” is opposite end termination location (telecommunications room) to which the cable routes, and ###-FT is the cable length.

For example:

- Indoor Riser: if a 24-strand singlemode fiber backbone cable were running between telecommunications rooms “M#” and “T#” and is 175 feet long, then the label for that cable in M# would read “24SM to T#, 175-FT” and the opposite end label for that cable in T# would read “24SM to M1”, 175-FT”.

- Outside Plant Backbone: if a 24-strand singlemode outside plant fiber backbone cable were running between Godfrey telecommunications room “M1” and Strode telecommunications room “M1”, and were 355 feet long, then the label for that cable in Godfrey “M#” would read “24SM to Strode M1, 355-FT” and the opposite end label for that cable in Strode telecommunications room “M1” would read “24SM to Godfrey M1, 355-FT”.
- E. Voice backbone (analog) patch panels shall have identifiers sequentially numbered in the form of “BC##” indicating the sequential copper patch panel number terminated within a given telecommunications room. The numbering sequence does not restart for each patch panel.
- F. INTENTIONALLY LEFT BLANK

- G. Horizontal copper cables and the faceplates of workstation outlets shall have identifiers in the form of “@#-#@##” where the first @ is the MDF “M) or TR “T” designation, # is the numerical designated IT Space, DASH, # is the rack (or cabinet) number, @ is patch panel alpha, and ## is the port number.
- For example: if an outlet on the telecom room designated as T2 has two Category 6A cables terminated in the 21st and 22nd ports in the 5th workstation patch panel (located in the 3rd rack) then the jacks in the faceplate and the cables behind the jacks would be labeled “T2-3E21 and T2-3E22 respectively. The faceplate would be labeled T2-3E21/E22.
- H. INTENTIONALLY LEFT BLANK
- I. INTENTIONALLY LEFT BLANK
- J. INTENTIONALLY LEFT BLANK
- K. Grounding and Bonding as recommended in ANSI/TIA/EIA 606. Grounding and Bonding Labeling Permanent (i.e. not subject to fading or erasure), industrial, permanently affixed, and created by a hand-carried label maker or a computer/software-based label making system. Handwritten labels are not acceptable.
- Label TMGB(s) with “TMGB”. If the TMGBs are existing and unlabeled, provide labels for each. Black on white, thermal transfer.
 - Label TGB(s) with “TGB”. If the TGBs are existing and unlabeled, provide labels for each. Black on

white, thermal transfer.

- Label TBB(s) and bonding conductors “WARNING! TELECOMMUNICATIONS BONDING CONDUCTOR. DO NOT REMOVE OR DISCONNECT!” Black on white, thermal transfer.
- Label connections for permanent grounding and bonding infrastructure for horizontal and backbone communications circuits, equipment racks, raceways, and cable trays at the busbar bonding, and approved building grounding conductors.
 - Example: MDF first rack should be labeled with label “M1-1”.
 - Example: TR number 1, second rack should be labeled with label “T1-2”.
 - Example: MDF ladder raceway should be labeled with label “M1 Ladder”.
 - Example: TR number 3 cable tray or wire basket tray should be labeled with label “T3 Tray” or “T3 Basket”.

L. INTENTIONALLY LEFT BLANK

3.10.1.2 MOVES, ADDS, AND CHANGES (MAC)

The only exception to the above identification scheme is for small projects relating to moves or changes to existing cabling, or the addition of new outlets terminated among other existing cables in existing TRs. In such cases (where the amount of new work is small compared to the overall system), the identification scheme for the new cables shall be consistent with the existing identification scheme.

For projects where there are larger amounts of change, the Designer shall inquire with Clemson whether it is desirable to re-label the existing cables when new cabling is being installed.

3.11 Field Testing of Structured Cabling

Please refer to Chapter 11, *Field Testing of Structured Cabling* in the BICSI TDMM for general information regarding the field testing of telecommunications cabling. The following requirements take precedence over the BICSI TDMM guidelines for field testing at Clemson facilities:

- A. The Designer shall require the Contractor to test 100% of field-terminated cabling.
 - Copper cables shall be permanent link-tested (not channel-tested).
- B. Cable tester equipment shall be manufactured by Fluke and have the most recent software revision and be calibrated within 365 days of the test.
- C. The Designer shall require the Contractor to submit the actual native machine test result files downloaded from the test equipment, and also the same test results in a PDF document. Printed (hard-copy) test reports are not necessary or desirable.
- D. The Designer shall review the cable test results submitted by the Contractor. In particular, the Designer shall check for the following items on the cable test reports:
 - The cable test report shall be automatically produced by the test equipment.
 - The report shall indicate that the cable passed the test. It shall also indicate the date of calibration, the software version, and the name of the technician that conducted the test. The reports shall also include graphical results of the performance curves obtained during the testing.
 - Indications that the cabling meets distance limitation requirements.
 - Indications that the wire-map of the cable is correct.
 - Indications that the cable test equipment was properly configured. For copper cabling, the test equipment's configuration parameter for Nominal Velocity of Propagation (NVP) shall match the value stated by the cabling manufacturer for the type of cable installed.
 - Marginal test results (typically indicated with an asterisk "**") are only acceptable when the condition is "over length" and when the over-length situation was intentional during design. For example, a low-bandwidth device

might be served by a cable that would otherwise be too long to support a high-bandwidth device. Over-length issues due to choice of routing or extra service loops are not acceptable.

- For fiber optic cabling, the cable test report shall indicate a headroom dB value that is equal to or better than the value calculated in the link-loss budget.
- E. The cabling performance characteristics shall meet or exceed the performance guaranteed by the manufacturer, which may exceed standard industry requirements. In other words, even though a particular cable might pass its tests, the cable might still be rejected (requiring re-termination or replacement) if it does not meet the higher standard of performance that the manufacturer may list for its products.
- F. Clemson may choose to spot-test cabling to back-check the Contractor's test results.
- G. Clemson may choose to hire a third-party cable test company to conduct an independent cabling test.
- H. The final test results shall have been verified by the Designer to be acceptable before submission to Clemson. Test results shall be submitted to Clemson in electronic form, both in PDF form and also the original test result data files.
- I. Contractors shall be required to retain a copy of the test reports for a period of at least 5 years after installation.

3.12 Outside Plant

Please refer to Chapter 12, *Outside Plant* in the BICSI TDMM and the BICSI OSPDRM for information regarding the design of outside plant telecommunications infrastructure.

See Section 3.4 *Backbone Distribution Systems* above.

3.13 Audio/Visual Systems

Please refer to Chapter 13, *Audiovisual Systems* in the BICSI TDMM for information regarding the design of telecommunications infrastructure to support audio/visual systems, private CATV distribution systems, and distributed paging systems at Clemson facilities.

3.13.1 AUDIO/VISUAL SYSTEMS

The Designer shall inquire with the AVTL for instructions about the telecommunications infrastructure required to support audio/visual applications at Clemson.

3.13.2 PRIVATE CATV DISTRIBUTION SYSTEMS

Clemson no longer provides conventional television (via coaxial cabling) to television locations on campus. Instead, IPTV is now used, requiring a single jack Category 6A outlet for each television location.

3.14 Building Automation Systems

Please refer to Chapter 14, *Building Automation Systems* in the BICSI TDMM for information regarding the design of telecommunications infrastructure to support building automation systems at Clemson facilities.

- A. ANSI/TIA/EIA-862 applies to telecommunications infrastructure serving building automation systems (BAS). The Designer shall pay particular attention to the following BAS issues:
 - Verify that the voltage and current requirements of each BAS application are satisfied by the cabling materials to be installed.
 - Verify that a suitable horizontal connection point (HCP) is installed for each BAS application.
- B. BAS devices are increasingly converging onto structured cabling systems. While the design of these systems is typically outside the scope of work of the telecommunications infrastructure designer, the Designer shall design the telecommunications cabling required to support these systems. Networks and infrastructure that are internal to the BAS are not required to comply with the TDDG. However, where BAS networks connect to the Clemson network, these connection points must comply.
- C. Typically, BAS systems require telecommunications cabling routed from the devices to a patch panel termination point in a designated mechanical room or other location managed by building maintenance personnel. In addition to the device-specific cables, other cables shall be designed from the telecommunications rooms to the BAS patch panels, to permit these systems to gain access to the data networks.
- D. Horizontal connection points are only required for BAS applications. Do not use an HCP for typical voice/data/video applications.

3.14.1 FIRE ALARM SYSTEM

- A. The Fire Alarm Control Panel (FACP) shall not be installed in a telecommunications room.

- B. The fire alarm system at Clemson’s campus communicates primarily via fiber optic cabling, however some buildings use analog phone circuits.
- C. The Designer shall include in the design two strands of singlemode fiber optic cabling (horizontal cable) between the FACP and the MDF. This cable shall be patched to the outside plant singlemode fiber backbone cable in coordination with the Owner to insert a new panel into the ring.
- D. The construction scope of work will likely include patching activities in other buildings outside of the new or remodeled building in order to connect the fire alarm system to an existing campus ring. The Designer shall include these requirements on the Contract Documents.

3.15 Data Networks Design

Please refer to Chapter 15, *Data Networks Design* in the BICSI TDMM for general information regarding the design of telecommunications infrastructure for serving local area networks. The following requirements take precedence over the BICSI TDMM guidelines for telecommunications infrastructure at Clemson facilities:

- A. All Clemson facilities use the Ethernet LAN protocol. Telecommunications infrastructure for all Clemson facilities shall be designed, installed, and tested to support the Institute of Electrical and Electronic Engineers (IEEE) Ethernet 802.3 standards. Clemson networks use the 1000Base-X Gigabit Ethernet protocol based on the IEEE 802.3z standard to the workstation and 10GBase-X in the backbone. All newly installed cabling shall support this protocol.
- B. The design of the network electronics is done by Clemson and is outside the scope of work of the telecommunications Designer.
- C. The Designer shall coordinate with the NSTTL to determine the requirements for supporting the network electronics in each space. The design shall provide rack space to host Clemson’s network equipment.

3.16 Wireless Networks

Please refer to Chapter 16, *Wireless Networks* in the BICSI TDMM and the BICSI Wireless Design Reference Manual (WDRM) for information regarding the design of telecommunications infrastructure to support wireless and microwave telecommunications systems at Clemson facilities.

3.16.1 ALL WIRELESS NETWORKS

The Designer shall alert the NSTTL about any new network or system that communicates via a wireless medium to be installed in a project. This includes building automation systems designed by mechanical engineers. All wireless systems need to be coordinated to ensure that new interference or conflict is not introduced into the existing campus spectrum environment.

3.16.2 WiFi NETWORKS

See Section 3.5.2.4 *Telecommunications Outlets for Wireless Access Points* for information about wireless access points.

3.16.3 DISTRIBUTED ANTENNA SYSTEMS

3.16.3.1 EMERGENCY RESPONDER RADIO

Clemson operates its campus radio system in cooperation with local emergency responders. The existing antenna network on campus is typically able to reach any location on campus. Therefore, the design of emergency responder-distributed antenna systems inside a building is not included in the scope of work. If it becomes necessary, Clemson will add its own system to a building after the project is completed.

The Designer shall include conduit pathway to the roof to support a future rooftop antenna should it become necessary.

3.16.3.2 CELLULAR TELEPHONE SERVICE AUGMENTATION

Currently, Clemson does not provide augmented cellular service coverage within its buildings, however, some of Clemson's facilities do have utility-provided distributed antenna systems (DAS) for this purpose. The Designer shall inquire with the NSTTL to determine whether utility-provided cellular service augmentation should be designed for a specific project, and shall incorporate any required supporting communications and power infrastructure within the design.

3.17 Electronic Safety and Security

Please refer to Chapter 17, *Electronic Safety and Security* in the BICSI TDMM for general information regarding the design of telecommunications infrastructure for serving electronic safety and security systems.

Electronic safety and security (ESS) devices are increasingly converging onto structured cabling systems. While the design of these systems may fall outside the scope of work of the telecommunications infrastructure designer, the Designer shall design the telecommunications cabling required to support these systems, and the telecommunications cabling subcontractor shall install the telecommunications cabling.

The diagrams at right depict the differences between two topologies that are typically used with ESS applications. The Designer shall inquire on a project-by-project basis

which solution to apply to a given project. Non-technical issues may affect which solution is used.

Sometimes ESS systems require telecommunications cabling routed from the devices to a patch panel termination point in a designated low-voltage electronics room (or other location managed by building security personnel). In addition to the device-specific cables, additional cables shall be designed from the telecommunications rooms to the ESS patch panels, to permit these systems to gain access to the data networks.

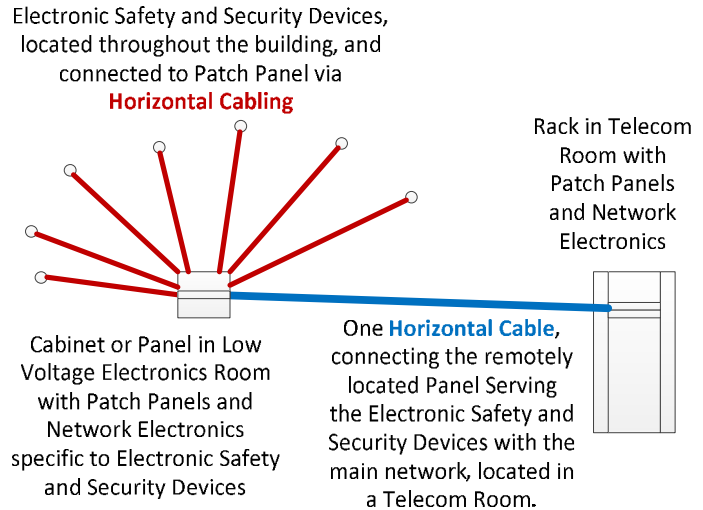

In other situations, ESS systems can be cabled directly to patch panels in the telecommunications rooms just like any other computer or telephone device.

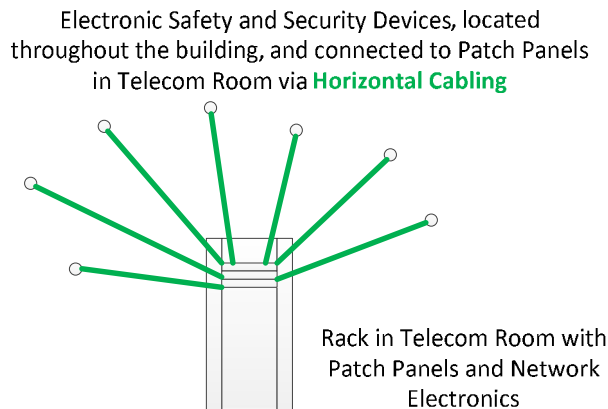

3.18 Data Centers

Please refer to Chapter 18, *Data Centers* in the BICSI TDMM for general information regarding the design of telecommunications infrastructure for serving data centers. Generally speaking, Clemson follows the TIA-942 Data Center Standard in the design of data centers and larger equipment rooms. The requirements below take precedence over the BICSI TDMM guidelines.

The requirements for small-scale equipment rooms are the same as for telecommunications rooms.

The Designer shall inquire with Clemson whether an equipment room in a given project is intended to be designed with telecommunications room features or data center features.

3.19 Health Care

Please refer to Chapter 19, *Health Care* in the BICSI TDMM for general information regarding the design of telecommunications infrastructure for serving health care facilities.

Clemson owns very few health care-related facilities. The likelihood of encountering a project of this type is low.

3.20 Residential Cabling

Please refer to Chapter 20, *Residential Cabling* in the BICSI TDMM for information regarding the design of telecommunications infrastructure to support residential facilities within Clemson facilities.

Generally speaking, Clemson-owned residential facilities shall be provided with the same telecommunications infrastructure materials and methods as are used for all other Clemson facilities, except where specifically noted in this document.

3.21 Business Development and Project Management

Please refer to Section 2 for project management requirements that are specific to Clemson.

Please refer to *Appendix A: Codes, Standards and Regulations* in the BICSI TDMM for general information regarding the codes, standards and regulations that apply to telecommunications infrastructure.

4 Construction Document Content

This section of the TDDG describes the content requirements that the Designer shall include when creating the Construction Documents. This content is in addition to the content found in some generally accepted document sets.

The services provided by the Designer and the resulting documents shall comply with the State of South Carolina's contract requirements. In addition to these requirements, the Designer shall also meet the requirements in this document, including the Construction Document content requirements in this section.

Construction Documents shall communicate a fully detailed and coordinated design (rather than making adjustments in the field during construction) and are expected to result in reduced construction costs and fewer change orders. The level of detail required to meet this objective may be substantially greater than some telecommunications designers may be accustomed to providing.

The Designer shall include the following content in the Construction Documents:

4.1 Plans and Drawings

4.1.1 GENERAL

The Construction Documents shall include the Division 27 requirements for the project detailed on T-sheets, including the following:

- Cover Sheet
- Sheet List
- Site Map
- Symbol Schedule
- List of Abbreviations
- Plan Sheets
- Elevation Diagrams
- Schematic Diagrams
- Construction Details
- Demolition

All plan sheets shall be drawn to scale, shall indicate the scale, and shall show a north arrow. All plan sheets shall show a key plan when the building or site is too large to fit on a single sheet.

Equipment and cable identifiers shall be shown on the drawings and diagrams.

4.1.2 OUTSIDE PLANT SITE PLAN DRAWINGS

- A. Provide drawings showing a scaled telecommunications distribution site plan. These drawings shall show the following:

- Maintenance hole or handhole locations (labeled with their identifiers)
 - Complete ductbank routing, details, and elevations
 - Conduit sizes, quantities, and arrangements
 - Section cuts
 - Existing and new surface conditions
 - Outside plant fiber optic telecommunications cabling, including fiber types and strand counts
 - Locations of buildings, roads, poles, existing underground utilities, and other obstructions
- B. The site plan shall show the cabling and pathway route to the building from which services will be derived.
- C. These sheets should also identify coordination arrangements where conflicts with site work for other disciplines could possibly arise, in particular indicating the separation distances between low-voltage pathways and power or steam. The sequencing of site work also should be shown, if applicable.

4.1.3 MAINTENANCE HOLE/HANDHOLE BUTTERFLY DIAGRAMS

- A. Butterfly diagrams are a combination of tabular information and a schematic diagram used to organize and communicate information related to the conduits and cabling in each maintenance hole and handhole. These diagrams are to be included in the project's drawing set.
- B. The Designer shall provide a set of butterfly diagrams depicting each maintenance hole or handhole affected by the project and showing new cabling as well as existing cabling to remain in the maintenance hole or handhole.
- C. Ducts to be used for new cabling shall be assigned during the course of design, not during construction. Duct assignments must be approved by Clemson prior to the release of the Construction Documents.
- D. A second set of butterfly diagrams shall be provided for each maintenance hole or handhole that contains existing cabling intended to be demolished under the project.
- E. The diagrams shall be formatted as shown in the sample butterfly diagram in Appendix 5.5. Upon request, Clemson will provide an electronic AutoCAD file of this diagram to be used as a template, as well as electronic CAD files for each butterfly diagram affected by a project.

4.1.4 INSIDE PLANT PLAN DRAWINGS

- A. Scaled plan drawings shall be provided for each building showing the telecommunications applications and cabling inside the building. These drawings shall show the following:

- Routing of new pathway to be constructed during the project.
 - The content of the drawings shall be coordinated with other disciplines and shall be representative of the complete pathway route that the Contractor shall use, rather than a schematic depiction.
 - It is expected that the Designer will expend considerable coordination effort during the design process. Non-coordinated pathway/raceway is not acceptable to Clemson.
 - Approximate locations of junction boxes and conduit bends.
 - The cable quantities and the raceway at any given point in the system.
 - Backbone distribution cabling (riser diagrams).
 - Grounding and bonding riser diagram.
- B. Where new cabling will be pulled into existing conduits, the Construction Documents shall show the routes of each *existing* conduit. Where it is not possible to determine the routing of existing conduits, the Designer shall inform the NSTTL and seek direction on whether to use the existing conduits or design new conduits for use on the project. Typically, the Designer is required to identify such conditions during field investigation activities.

4.1.5 DEMOLITION

- A. Any existing equipment and cabling intended to be no longer in use following the new installation shall be removed (salvaged and returned to the Owner undamaged and in working condition) as a part of the project. Clemson uses salvaged equipment as spare parts to support the existing equipment in other buildings.
- B. Existing cabling to be demolished shall be shown on the plans and schematic diagrams. Separate demolition plan sheets and schematic diagrams shall be provided for projects with extensive cable demolition.

4.1.6 TELECOMMUNICATIONS ROOM PLAN DETAILS

- A. Construction Documents for Clemson projects shall show scaled plan drawing details for the telecommunications spaces. The details shall show the footprint and location of each of the major components in the room, including at least the following:
- Backboards
 - Ladder Racking
 - Work Area
 - Entrance Conduits
 - UPS Equipment
 - Termination Blocks
 - Grounding Busbar
 - Space Reserved for Utility Demarc
 - Backbone Cable Routing
 - Racks and Vertical Cable Management
 - Space for other low-voltage systems
 - Entrance Protection Equipment
 - PBX and Voice Mail Equipment

- B. For modifications to existing telecommunications rooms, it may be necessary to provide a demolition plan.
- C. Sample telecommunications room plan diagrams are included in Appendix 5.3.

4.1.7 ELEVATION DIAGRAMS

- A. The Designer shall provide scaled wall elevation details for each MDF and IDF/TR affected by the project.
- B. For remodel projects, the Designer shall produce digital photographs of each wall depicting the existing conditions where the future MDF and IDFs will be located. These photos shall be provided with the wall elevation details in the Construction Documents.
- C. The wall elevation details shall show the components that are mounted on the walls in the room, including at least the following:
 - Backboards
 - Ladder Racking
 - Cable Slack Loops
 - Grounding Busbar
 - Existing Devices
 - Work Area
 - Cable Management
 - Termination Blocks
 - Power Receptacles
 - Entrance Conduits
 - PBX and Voice Mail
 - UPS
 - Entrance Pit
 - Backbone Cable Routing
 - Space for Future Racks
 - Wall-mounted Electronic Equipment
 - Wall-mounted Swing Racks & Contents
 - Racks and Vertical Cable Mgmt
 - Entrance Protection Equipment
 - Other low-voltage systems
 - Space for Future Equipment
 - Space Reserved for Utility Demarc
- D. Elevation details for each of the telecommunications racks in the MDF and each IDF shall also be provided. Rack elevation details shall show the racks and any components that are mounted on or near the racks including at least the following:
 - Patch Panels
 - UPS Equipment
 - Shelves/Drawers
 - Termination Blocks
 - Power Receptacles
 - Existing Devices
 - Space for Future Equipment
 - Electronic Equipment
 - Cable Management
- E. The details shall depict the telecommunications materials that are listed in the specification.
- F. Where a project involves additions to existing racks, the elevation details shall show the existing equipment in the racks and indicate which items are existing, in addition to indicating which items are “new, to be provided under the Contract.”
- G. Examples of rack elevation details are included in Appendix 5.2. An example

wall elevation detail is included in Appendix 5.4.

4.1.8 INTRA-BUILDING BACKBONE SCHEMATIC DIAGRAMS

- A. A schematic diagram shall be provided showing the sizing and routing of fiber optic and copper backbone cables.
- B. On projects where existing intra-building distribution cabling is to be removed, it may be useful to provide a separate schematic diagram depicting cabling to be demolished.

4.2 Project Manual

- A. The State of South Carolina’s Office of State Engineer publishes a document titled “Manual for Planning and Execution of State Permanent Improvements.” The design and resulting document set shall meet the requirements in this document.
 - <https://procurement.sc.gov/manual>
- B. In addition to these requirements, the Project Manual shall contain the following items as described below:
 - Horizontal Cabling Labeling Spreadsheet
 - Fiber Link-Loss Budget Analyses
 - Cutover Plans

4.2.1 SPECIFICATIONS

4.2.1.1 CLEMSON TELECOMMUNICATIONS CONSTRUCTION GUIDE SPECIFICATION

- A. The Clemson Telecommunications Construction Guide Specification (TCGS) is a *guide* specification as opposed to a *master* specification. It does not include an exhaustive listing of all possible products or installation methods that could be employed in a telecommunications infrastructure project.
- B. The TCGS is an example of a specification that shall be used for an infrastructure replacement project or for a new facility project. It has verbiage that identifies issues that the Designer shall consider throughout the adaptation process. The Designer shall adapt the sections in the TCGS to the particular requirements of the given project.
- C. The Designer shall directly edit the TCGS for use on each project. The Designer shall notify the NSTTL where changes or additions to the specifications are desired. Edits to the documents shall be performed with the “Revision Tracking” feature activated. At the various project milestones when the documents are submitted to Clemson for review, the specifications shall be printed showing the revision markings.

- D. The Designer shall be responsible for adding any necessary content to the specification that is applicable to the project and not already contained in the TCGS.
- E. Please refer to the more detailed instructions contained in the TCGS, both in the Preface of that document as well as in the “hidden text” comments contained in the electronic files.

4.2.1.2 COMMON SPECIFICATION SECTIONS

There are several specification sections that are commonly used for telecommunications systems or contain content that supports telecommunications functionality.

Sections typically provided by the Architect, but requiring Designer input:

- 09 91 00 – Painting
- 07 84 00 – Firestopping

Sections typically provided by the Telecommunications Engineer:

- 27 05 00 – Common Work Results for Communications
- 27 05 26 – Grounding and Bonding for Communications Systems
- 27 05 29 – Hangers and Supports for Communications Systems
- 27 05 33 – Conduits and Backboxes for Communications Systems
- 27 05 36 – Cable Trays for Communications Systems
- 27 11 00 – Communications Equipment Room Fittings
- 27 13 00 – Communications Backbone Cabling
- 27 15 00 – Communications Horizontal Cabling
- 27 16 00 – Communications Connecting Cords, Devices, and Adapters
- 27 32 00 – Voice Communication Telephone Sets
- 33 81 26 – Communications Underground Ducts, Manholes, and Handholes
- 33 82 00 – Communications Distribution
- 33 82 43 – Grounding and Bonding for Communications Distribution

4.2.2 CUTOVER PLAN

The Designer shall provide a detailed Cutover Plan that is coordinated with other disciplines on the project as well as with Clemson data and telephone equipment cutover requirements. Verbiage describing the sequence of work tasks to accomplish the cutover shall be provided in this section. Limitations on the permissible downtime allowed and temporary service arrangements shall be discussed in the Cutover Plan.

The Cutover Plan shall also include a rollback strategy to enable reversion to the existing system if a problem develops that is serious enough to render cutover unfeasible.

Not all projects will require a Cutover Plan.

4.2.3 FIBER LINK-LOSS BUDGET ANALYSIS

- A. The Designer shall provide (in the Construction Documents) a link-loss budget analysis for each fiber optic cable.
- B. The link-loss budget analysis shall be formatted as shown in Appendix 5.6 of the TDDG. Upon request, Clemson will provide an electronic spreadsheet file to be used as a template.

4.3 Record Drawings and Documentation

The State of South Carolina DES publishes requirements for Record Drawings and submittals. The following requirements related to Record Drawings and submittals are **in addition** to those published by the State:

4.3.1 RECORD DRAWING CONTENT

The Record Drawings shall show the identifiers for the telecommunications equipment and cabling as constructed.

4.3.2 RECORD DRAWING DELIVERABLES

The original copy of hard-copy as-built and record drawings shall be provided to CCIT-NSTand Clemson Facilities.

5 Appendix

5.1 Cable Color Scheme

The following graphic depicts the approved cable color scheme for Clemson projects:

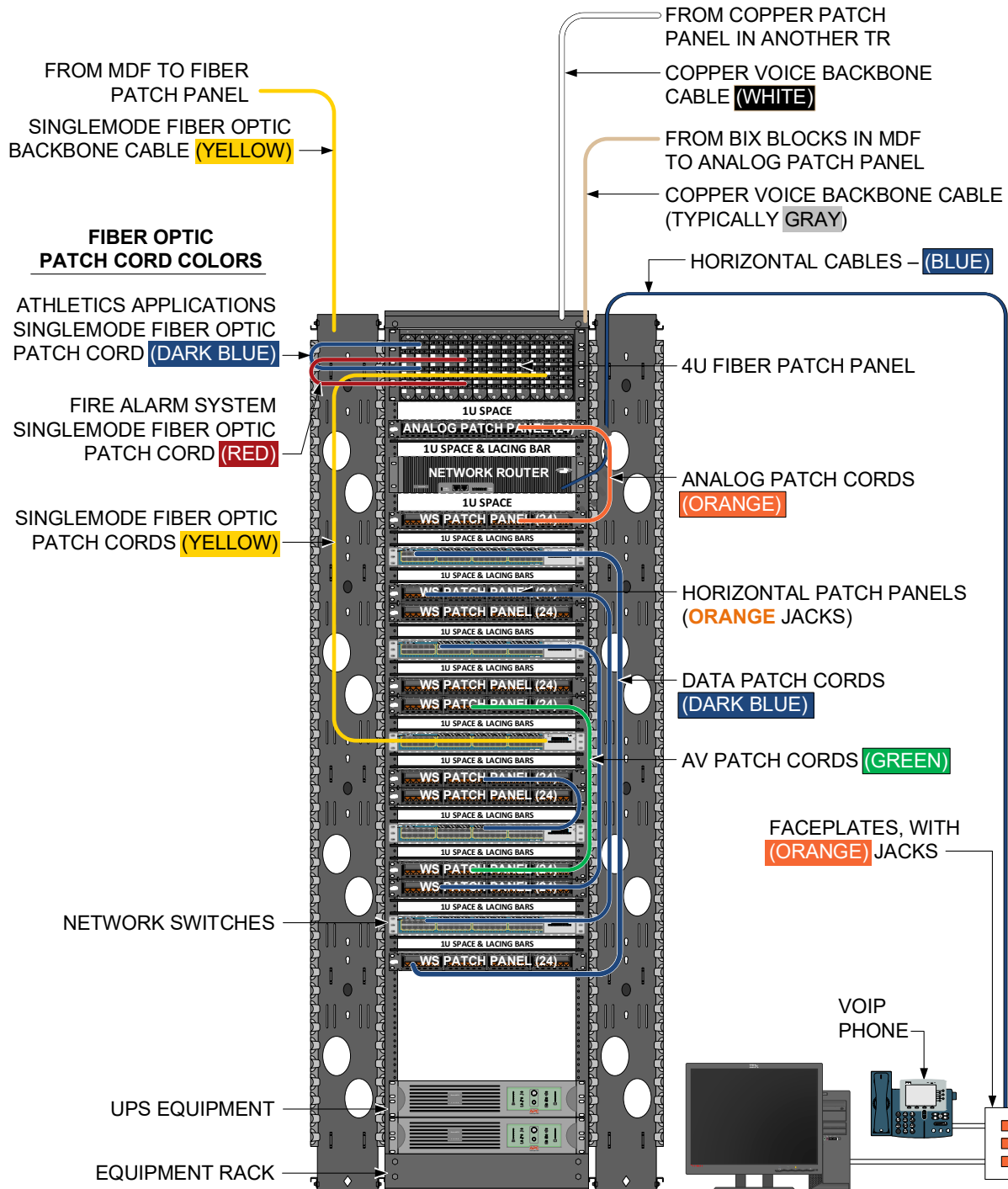

5.2 Sample Rack Elevation Details

The Designer shall provide scaled rack elevation details in the project drawings (similar to the details below), and shall identify the racks, vertical and horizontal cable management, patch panels, shelves and drawers in each detail. The drawings below depict maximum Day-1 design capacity, with accommodations for future growth shown in outline form.

Note that the designated contents in each rack are intentionally arranged for optimal operational considerations. If the adjacent wall is on the left side of a row of multiple racks, the designer shall invert the arrangement.

5.2.1 TWO RACKS

This example is suitable for a Day-1 design with a maximum of 320 horizontal cables (leaving room for future growth).

A two-rack room is rarely adequate, because it has very limited space for future equipment or cabling to be added. Therefore, it shall only be used as a last resort, and then only with the approval of the NSTTL.

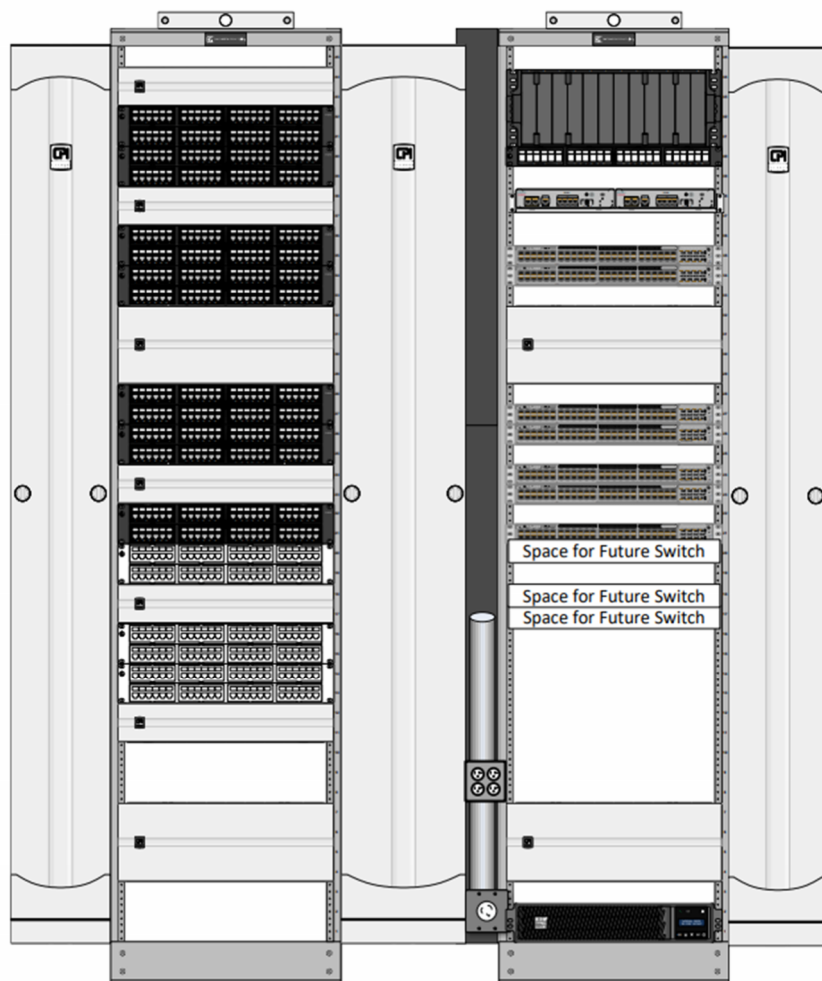

Rack 1
Horizontal

Rack 2
**Fiber Optic, Analog Voice
 & Network Electronics**

5.2.2 THREE RACKS

This example is suitable for a Day-1 design with a maximum of 528 horizontal cables (leaving room for future growth).

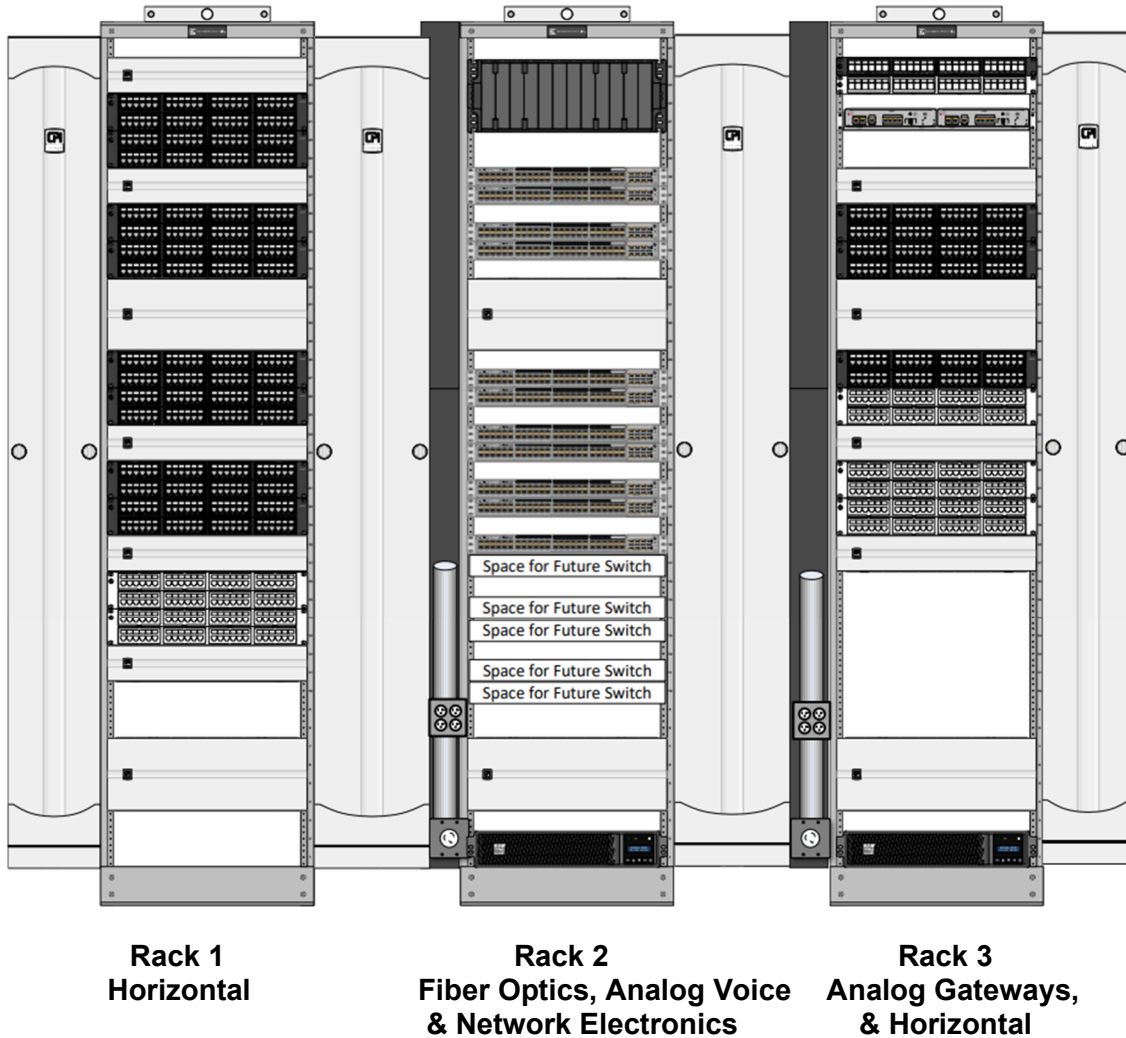

5.2.3 FOUR RACKS

This example is suitable for a Day-1 design with a maximum of 720 horizontal cables (leaving room for future growth).

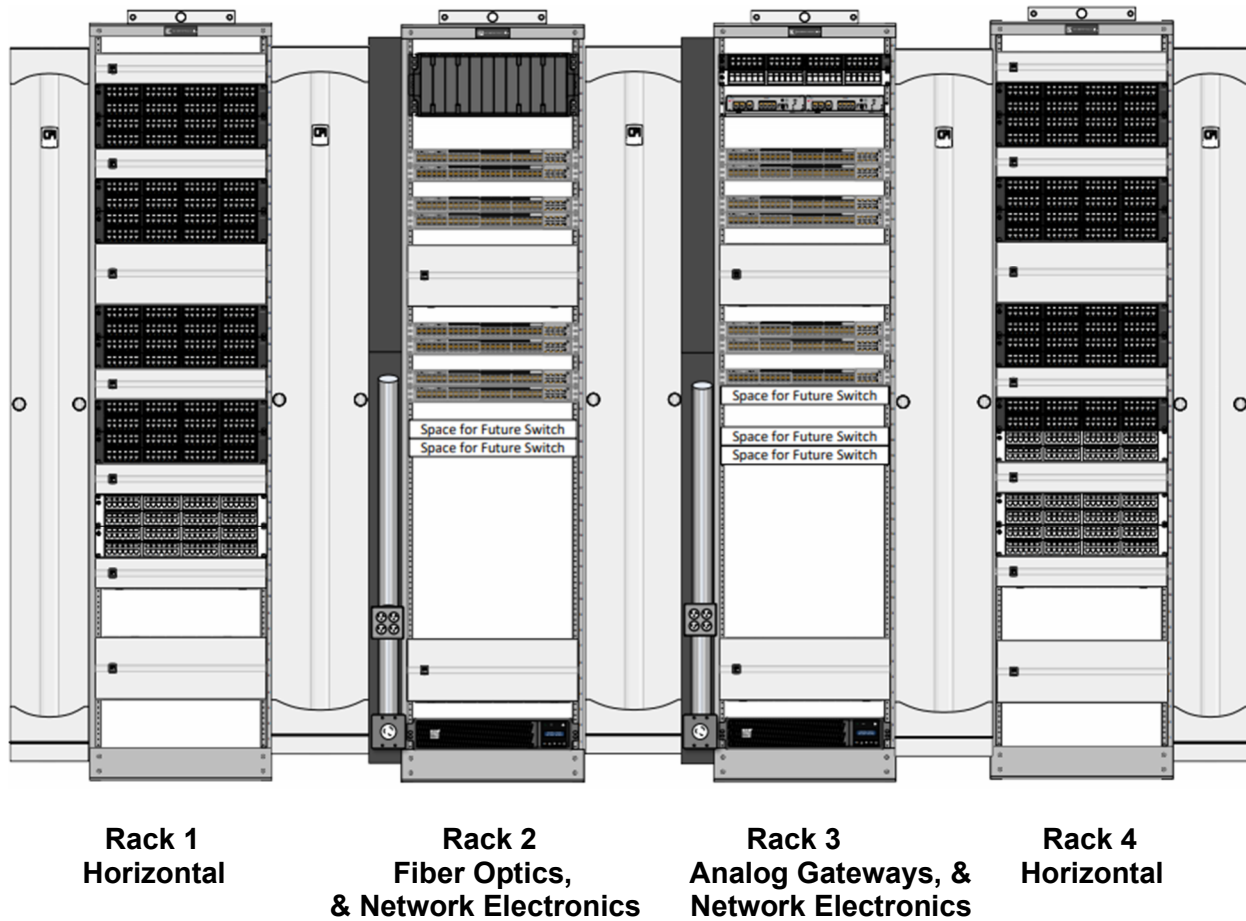

5.2.4 FIVE RACKS AND SIX RACKS

Some applications may require telecommunications rooms supporting five or six racks. These cases typically involve rack-mounted audio/visual or other systems sharing space in the telecommunications rooms. Clemson anticipates that no more than four telecommunications racks will be required for most telecommunications rooms at its facilities.

5.3 Sample Telecommunications Room Plan Details

Below are sample plan details for several sizes of telecommunications rooms. The Designer shall provide similar details and information for each telecommunications room and equipment room affected by the project. This information shall be provided in the Construction Documents.

These sample plan details have been pre-approved for use at Clemson. The Designer shall use this layout wherever appropriate and shall discuss project-specific alternatives with the NSTTL.

The room dimensions shown are considered to be acceptable minimums.

5.3.1 Two Racks – 10' x 10' (INTERIOR DIMENSIONS)

This example is suitable for a Day-1 design with a maximum of 320 horizontal cables (leaving room for future growth).

A two-rack room is rarely adequate, because it has very limited space for future equipment or cabling. Therefore, it shall only be used as a last resort, and then only with the approval of the NSTTL.

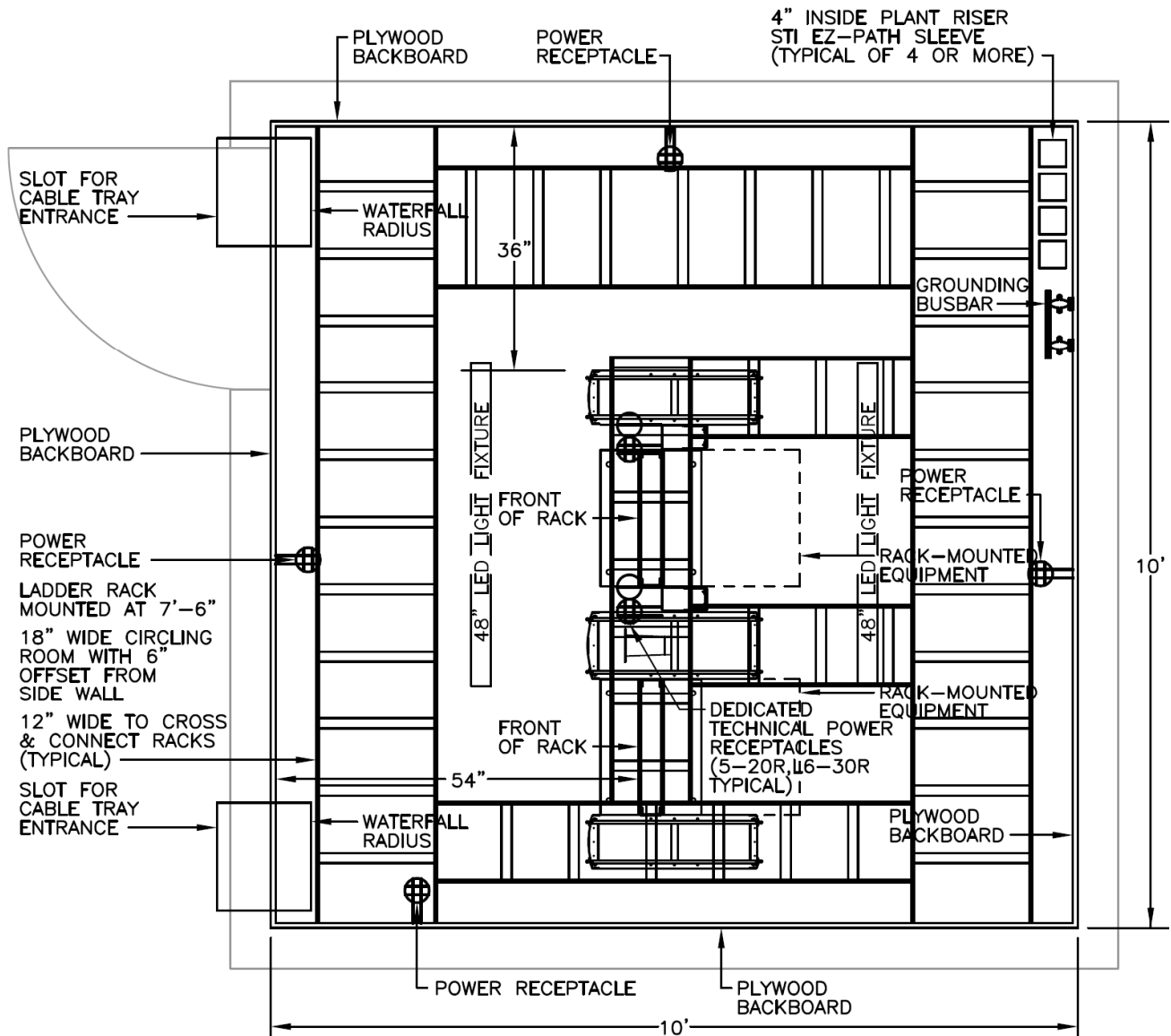

5.3.2 THREE RACKS – 10' X 12' 6" (INTERIOR DIMENSIONS)

This example is suitable for a Day-1 design with a maximum of 528 horizontal cables (leaving room for future growth).

This is the standard IDF configuration.

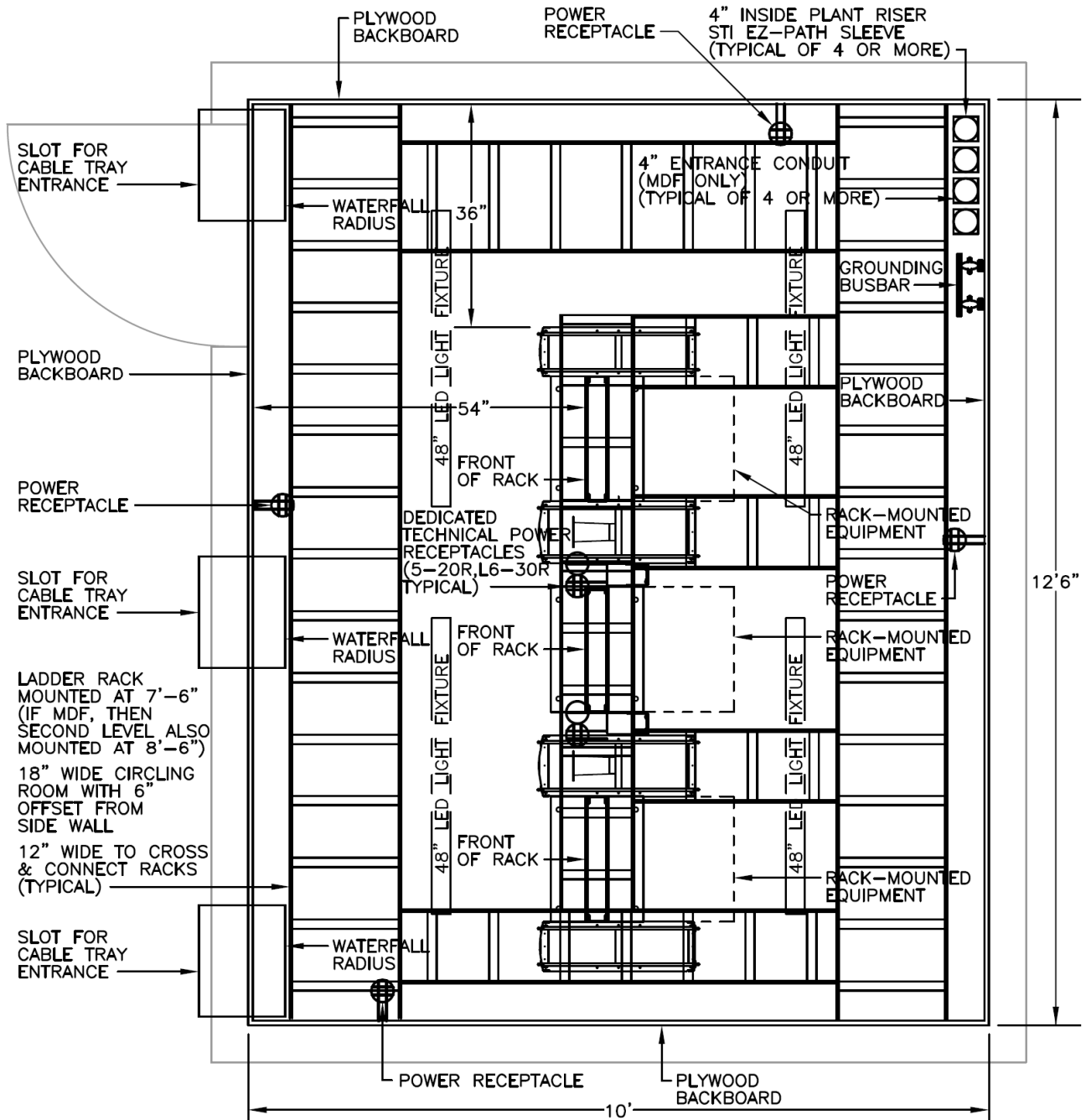

5.3.3 FOUR RACKS – 10' x 15' (INTERIOR DIMENSIONS)

This example is suitable for a Day-1 design with a maximum of 720 horizontal cables (leaving room for future growth).

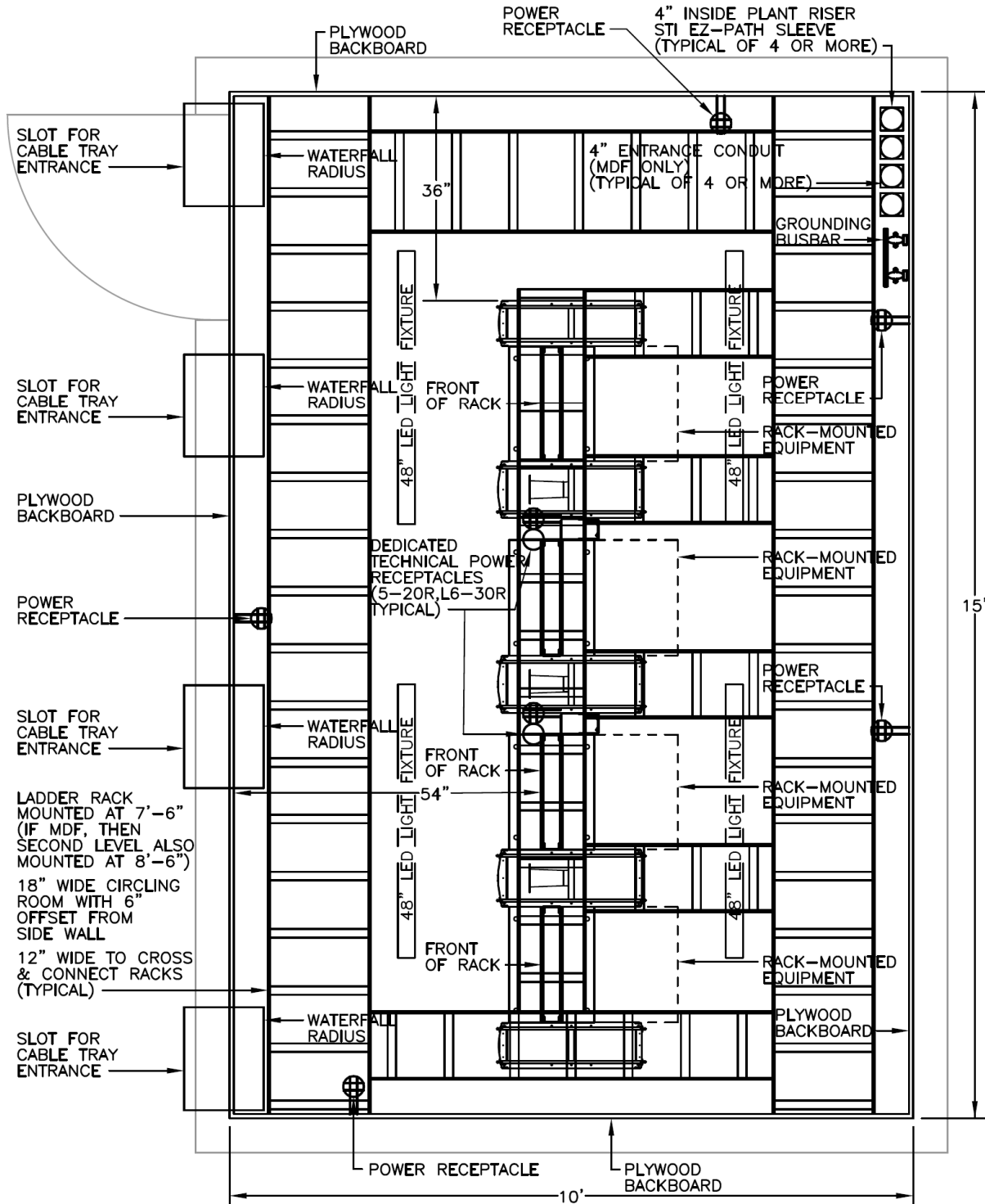

5.4 Sample Wall Elevation Detail

The Designer shall provide a scaled wall elevation detail, similar to the example below, for each new or existing telecommunications room wall affected by the project.

This information shall be provided in the Construction Documents.

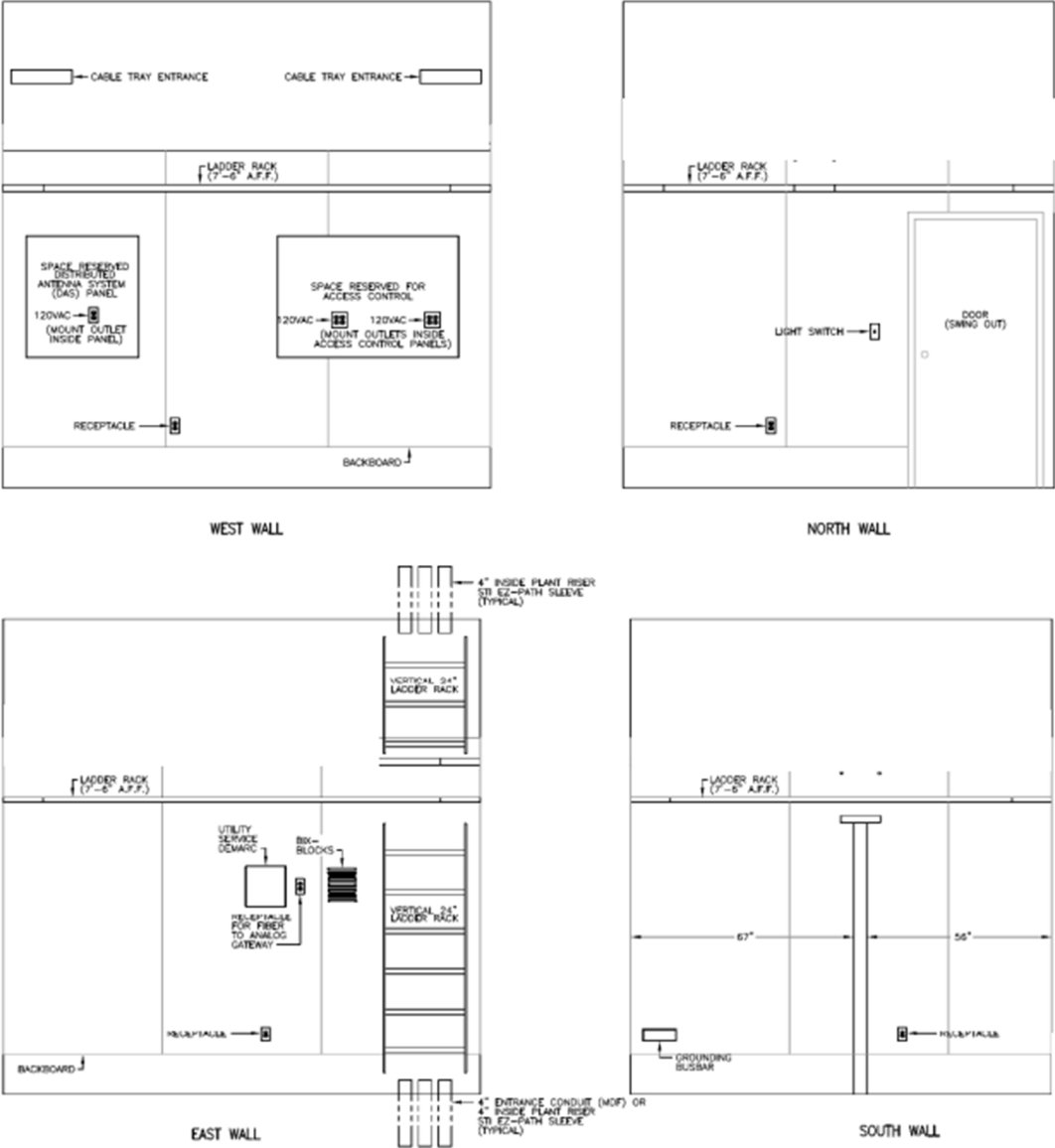

5.5 Sample Maintenance Hole Butterfly Diagram

For each outside plant handhole, pull hole and maintenance hole affected by a project (existing or new), the Designer shall provide a butterfly diagram similar to the example below:

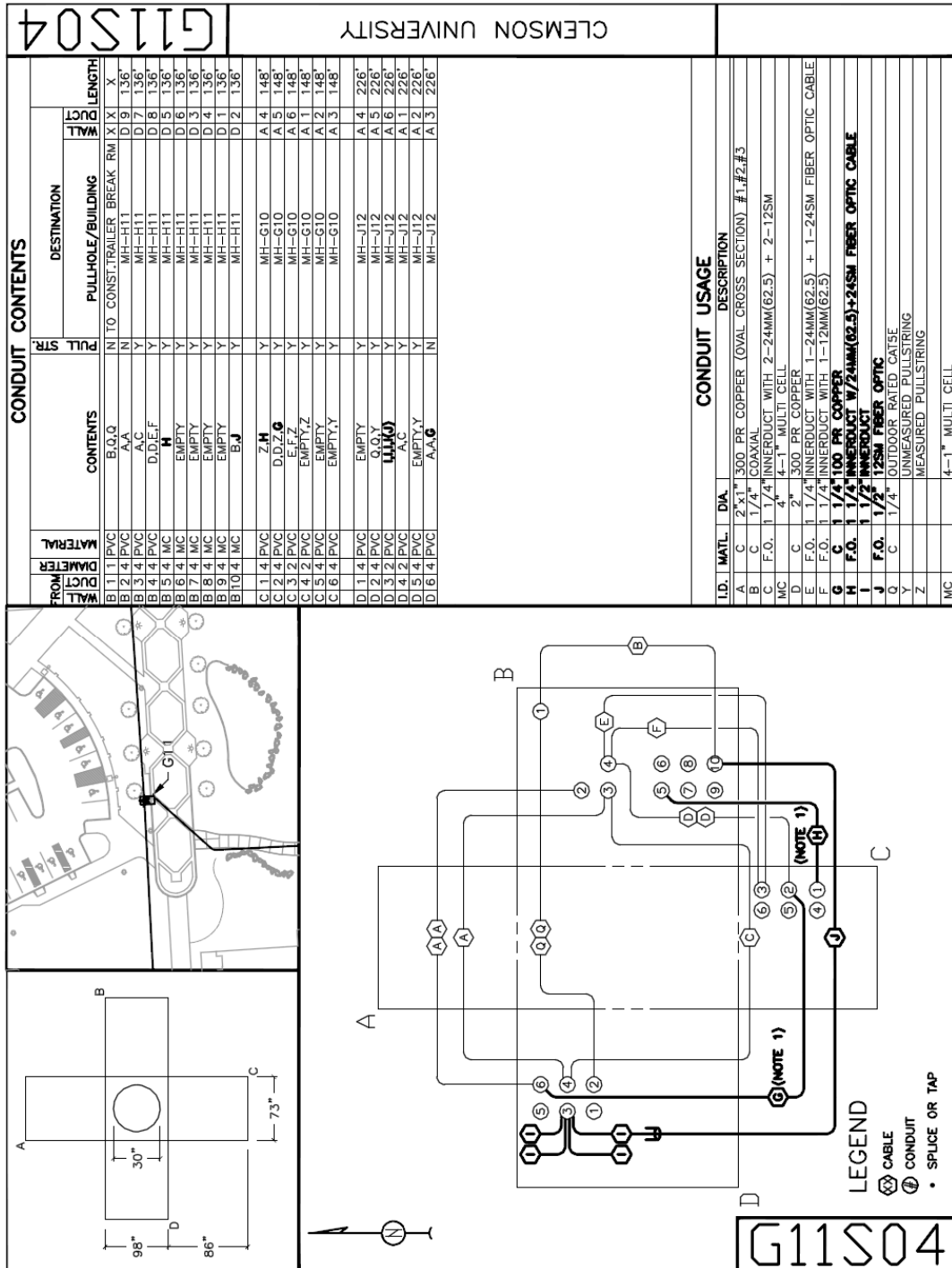

5.6 Sample Fiber Optic Link-Loss Budget Analysis

The following is a sample Fiber Optic Link-Loss Budget Analysis that the Designer shall use for each new fiber optic cable designed in the project. The Designer shall submit the completed link-loss budget analyses to Clemson in

both electronic and paper forms. Upon request, Clemson will provide an electronic spreadsheet of this form to be used as a template.

Cable ID:	Enter Cable ID Here		# of MM Strands
From:	Enter MDF/Building Name Here		# of SM Strands
To:	Enter IDF/Building Name Here		

		MM 850	MM 1300	SM 1310	SM 1550	
Passive Cable System Attenuation						
Fiber Loss at Operating Wavelength	Cable Length (in kilometers)					km
	x Attenuation per km	x 3.75	x 1.5	x 0.5	x 0.5	dB/km
	= Total Fiber Loss	= 0.00	= 0.00	= 0.00	= 0.00	dB
Connector Loss (Excluding Tx & Rx Connectors)	Number of Connector Pairs	2	2	2	2	pairs
	x Individual Connector Pair Loss	x 0.5	x 0.5	x 0.5	x 0.5	dB/pair
	= Total Connector Loss	= 1.00	= 1.00	= 1.00	= 1.00	dB
Splice Loss	Number of Splices					splices
	x Individual Splice Loss	x 0.3	x 0.3	x 0.3	x 0.3	dB/splice
	= Total Splice Loss	= 0.00	= 0.00	= 0.00	= 0.00	dB
Other Components Loss	Total Components Loss					dB
Total Passive Cable System Attenuation	Total Fiber Loss	0.00	0.00	0.00	0.00	dB
	+ Total Connector Loss	+ 1.00	+ 1.00	+ 1.00	+ 1.00	dB
	+ Total Splice Loss	+ 0.00	+ 0.00	+ 0.00	+ 0.00	dB
	+ Total Components Loss	+ 0.0	+ 0.0	+ 0.0	+ 0.0	dB
	= Total System Attenuation	= 1.00	= 1.00	= 1.00	= 1.00	dB
Link Loss Budget						
From Manufacturer's Specifications	Average Transmitter Output	-18.0	-18.0	-18.0	-18.0	dBm
	Receiver Sensitivity (10 ⁹ BER)	-31.0	-31.0	-31.0	-31.0	dBm
System Gain	Average Transmitter Power	-18.0	-18.0	-18.0	-18.0	dBm
	- Receiver Sensitivity	- -31.0	- -31.0	- -31.0	- -31.0	dBm
	= System Gain	= 13.00	= 13.00	= 13.00	= 13.00	dB
Power Penalties	Operating Margin	2.0	2.0	3.0	3.0	dB
# of Fusion Splices	+ Receiver Power Penalties	+ 0.0	+ 0.0	+ 0.0	+ 0.0	dB
Loss per Splice	+ Repair Margin	+ 0.6	+ 0.6	+ 0.6	+ 0.6	dB
2 x 0.3 =	= Total Power Penalties	= 2.60	= 2.60	= 3.60	= 3.60	dB
Link Loss Budget	System Gain	13.00	13.00	13.00	13.00	dB
	- Power Penalties	- 2.60	- 2.60	- 3.60	- 3.60	dB
	= Total Link Loss Budget	= 10.40	= 10.40	= 9.40	= 9.40	dB
Performance						
System Performance Margin	Link Loss Budget	10.40	10.40	9.40	9.40	dB
	- Passive Cable System Attenuation	- 1.00	- 1.00	- 1.00	- 1.00	dB
	= System Performance Margin	= 9.40	= 9.40	= 8.40	= 8.40	dB

Users of this spreadsheet shall verify prior to use that the parameters and calculations are appropriate for the project, equipment, and materials that are used.

5.7 Acronym Glossary

A/E	Architect/Engineer
A/V	Audio/Visual
ACTL	Access Control Technical Lead
AVTL	Audio/Visual Technical Lead
BATL	Building Automation Technical Lead
BIM	Building Information Model
CCIT	Clemson Computing & Information Technology
CDF	Controlled-density fill
CGS	Construction Guide Specification
CGSP	Construction Guide Specification Preface
CMU	Concrete masonry unit
EMI	Electromagnetic interference
ESS	Electronic Safety and Security
FF&E	Furniture, fixtures, and equipment
FPM	Facilities Project Manager
GC/CM	General Contractor/Construction Manager
GPON	Gigabit Passive Optical Network
HC	Horizontal cross-connect
HCP	Horizontal connection point
IC	Intermediate cross-connect
IDF	Intermediate Distribution Frame (secondary telecommunications rooms)
ISP	Inside plant
MC	Main cross-connect
MAC	Moves, adds, or changes
MDF	Main Distribution Frame (main telecommunications room in the building)
NST	Network Services and Telecommunications department (within CCIT)
NSTTL	CCIT Network Services and Telecommunications Technical Lead
O.D.	Outside Diameter
OLT	Optical Line Termination
ONT	Optical Network Terminal
OSP	Outside plant
PDU	Power distribution unit
POE	Power over Ethernet
RCDD	Registered Communications Distribution Designer

RFI	Radio frequency interference
SVR	Standards Variance Request
TCGS	Telecommunications Construction Guide Specification
TDDG	Telecommunications Distribution Design Guide
TGB	Telecommunications grounding busbar
TR	Telecommunications room
UTC	Undercarpet telecommunications cabling
UTP	Unshielded twisted pair
WAP	Wireless access point